



Increased Safety

Ex MOTORS

Industrial Application

A dynamic, strong and ambitious Group

Orange1 Holding is an international renown Group, one of the most important European manufacturers of single-phase and three-phase asynchronous electric motors. It has an annual capacity of more than 1 million motors and 5 million electric stators. The group, established in 1971 by Leone Donazzan, chaired today by his son Armando Donazzan, is strongly focused on technological innovation, performance and customization to meet individual clients requirements.





Elettromeccanica Leone Donazzan was established on 1971 in Bassano del Grappa. In 1983 the company turned into Eld Spa. In 1998 Armando Donazzan took over the running of the company; thanks to his determination and intuition he applied new financial and commercial policies which increased the level of reliability and visibility. In March 2006 the company changed its name to EME Spa and finally become Orange1 Electric Motors in 2018. The aim of OIEM is to manufacture custom made motors to meet clients and market expectations. The actual production covers a large range of AC and DC motors, as well as brushless motors and Variable Frequency Drives , to provide total solution.

PRODUCTION PLANTS

LOCATION	MOTORS PRODUCTION
<p>ARSIÈ - ITALY 32030 (BL) Via A. Messedaglia 4</p>	<p>SINGLE AND THREE PHASE MOTORS HOLLOW SHAFT MOTORS IE2 AND IE3 MOTORS INVERTER AND MOTORINVERTER</p>
<p>S. MAURO PASCOLI - ITALY 47030 (FC) Via A. Grandi 23</p>	<p>GRADUAL BRAKE MOTORS HIGH TORQUE BRAKE MOTORS LOW CENTER MOTORS MOTORS FOR BURNERS</p>
<p>PARMA - ITALY 43122 (PR) Via Mantova 93</p>	<p>ATEX MOTORS HYDRAULIC MOTORS ENCAPSULATED WATERPROOF MOTORS OIL SUBMERGED MOTORS</p>

INDEX

1. TOLERANCES AND STANDARDS OF REFERENCE	5
1.1 Mechanical and Electrical tolerances Symbol	5
1.2 Standards of reference	5
2. GUIDE TO MOTOR CHOICE	6
3. General informations	7
3.1 Range of motors	7
3.2 Testing and certificates	10
3.3 Main features	10
3.4 Main options	11
4. TERMINAL BOX, CABLE ENTRIES AND CONNECTIONS	13
5. MECHANICAL CHARACTERISTICS	14
5.1 Radial and axial forces on the shaft end	14
5.1.1 Permissible radial load	15
5.1.2 Permissible axial load (with additional radial load applied at the end of the shaft)	15
6. ELECTRICAL DATA	16
6.1. Motors for ATEX Zones 1, 21 (Increased safety 'Ex eb', protection by enclosure 'tb' IIIC)	16
6.1.1. Three-phase motors, 1 speed	16
6.1.2 Single-phase motors, 1 speed	18
6.2. Motors for ATEX Zones 2, 22 (Non-sparking 'Ex ec', protection by enclosure 'tc' IIIB)	19
6.2.1 Three-phase motors, 1 speed	19
6.2.2 Single-phase motors, 1 speed	21
7. OVERALL DIMENSIONS	22
8. Spare Parts	25
8.1 Personnel qualification	25
8.2 Spare parts	25

Potential Explosive Atmospheres - ATEX

Increased Safety



1. Tolerances and standards of reference

1.1 Mechanical and Electrical tolerances Symbol

Symbol	Description	Tolerance	
A	Distance between centre-lines of fixing holes (end view)	± 1 mm	
AB	Overall dimensions across the feet (end view)	2%	
AC	Diameter of the motor (without terminal box)	2%	
B	Distance between centre-lines of fixing holes (side view)	± 1 mm	
C - CA	Distance from the shaft end shoulder to the centre-line of nearest mounting holes in the feet	± 3 mm	
D - DA	Diameter of the shaft extension.	∅ 11 – 28	J6
		∅ 32 – 48	K6
		∅ ≥ 55	M6
E - EA	Length of the shaft extension from the shoulder	∅ < 55 mm	
F - FA	Width of the keyway of the shaft extension	∅ > 60 mm	
GA - GC	Distance from the top of the key to the opposite surface of the shaft extension	+ 0,2 mm	
H	Distance between the centre-line of the shaft to the bottom of the feet	H ≤ 250	- 0,5 mm
		H ≥ 280	- 1 mm
HD	Distance from the top of the terminal box and to the bottom of the feet	2%	
K	Diameter of the holes or width of the slots in the feet of the motor	3%	
L	Overall length of the motor with a single shaft extension	1%	
M	Pitch circle diameter of the fixing holes	± 0,8 mm	
N	Diameter of the spigot	∅ < 230	j6
		∅ ≥ 250	h6
P	Outside diameter of the flange	± 1 mm	
R	Distance from the shaft shoulder to the mounting surface of the flange	± 3 mm	
S	Diameter of the fixing holes in the mounting flange or nominal diameter of thread	3%	
	Distance from the shaft shoulder to the mounting surface of the flange with locked bearing	± 0,5 mm	
	Mass of the motor	- 5 a + 10 %	
Nominal voltage, V _N		±5%	
Efficiency, η		-15% of (1-η)	
Power factor, cos φ		-1/6 of (1-cos φ)	
Slip (rpm) (full load and nominal ambient temperature), P _N		min 0.02, max 0.07	
Locked rotor current, I _A		±20% if P _N ≥ 1 kW	
Locked rotor torque, M _A		±30% if P _N < 1 kW	
Breakdown torque, M _{max}		20%	
Minimum torque, M _{min}		0,1	
Moment of Inertia, J		-10% con M _{max} /M _N ≥ 1.6	
Sound intensity level (sound pressure) L _{pFA}		-15%	
		±10%	
		+3 dBA	

1.2 Standards of reference

Title	EU CENELEC	International IEC
Rotating electrical machines - Part 1: Rating and performance	EN 60034-1	IEC 60034-1
Rotating electrical machines Part 2-1: Standard methods for determining losses and efficiency from tests (excluding machines for traction vehicles)	EN 60034-2	IEC 60034-2
Rotating electrical machines. Part 5: Degrees of protection provided by the integral design of rotating electrical machines (IP code). Classification	EN 60034-5	IEC 60034-5
Rotating electrical machines - Part 6: Methods of cooling (IC Code)	EN 60034 -6	IEC 60034 -6
Rotating electrical machines Part 7: Classification of types of construction, mounting arrangements and terminal box position (IM Code)	EN 60034-7	IEC 60034-7
Rotating electrical machines - Part 9: Noise limits	EN 60034-9	IEC 60034-9
Rotating electrical machines - Part 12: Starting performance of single-speed three-phase cage induction motors	EN 60034-12	IEC 60034-12
Rotating electrical machines - Part 14: Mechanical vibration of certain machines with shaft heights 56 mm and higher - Measurement, evaluation and limits of vibration severity	EN 60034-14	IEC 60034-14
General purpose three-phase induction motors having standard dimensions and outputs. Frame numbers 56 to 315 and flange numbers 65 to 740	EN 50347	IEC 60072-1
Degrees of protection provided by enclosures (IP Code)	EN 60259	IEC 60529
Electrical apparatus for explosive gas atmospheres - Part 0: General requirements	EN 60079-0	IEC 60079-0
Electrical apparatus for explosive gas atmospheres - Part 7: Increased safety "e"	EN 60079-7	IEC 60079-7
Electrical apparatus for use in the presence of combustible dust - Part 0: General requirements	EN 61241-0	IEC 61241-0
Electrical apparatus for use in the presence of combustible dust - Part 1: Protection by enclosures "tD"	EN 61241-1	IEC 61241-1

Potential Explosive Atmospheres - ATEX

Increased Safety



2. Guide to motor choice

First step is the classification of hazardous places in zones. The end user shall classify the hazardous areas under his own responsibility. Directive 1999/92/EC provides information regarding 'Classification of places where explosive atmosphere may occur. The corresponding standards of reference are EN 60079-10 for gas and EN 61241-10 for dust.

Here below we give you a synthetic step by step guide to the choice of the motors. We will highlight all the characteristics of our motors.

Zone Classification (presence of explosive atmosphere)		Electrical apparatus ATEX marking					
		(1) Group	(2) Category	(3) Type of protection	(4) Gas group Dust group	IP Degree	(5) GAS Temperature class (6) DUST Surface temperature
GAS	0	Present continuously or for long period	II	1G	Electrical apparatus not allowed		
	1	Occur in normal operation occasionally	II	2G	Ex eb 'increased safety'	IIA, IIB, IIC	IP54
					Ex db 'flameproof enclosure'		-
2	Rarely occur in normal operation and for short period	II	3G	Ex ec 'Non Sparking'	IIA, IIB, IIC	IP54	T1=450°C T2=300°C T3=200°C T4=135°C T5=100°C T6=85°C
DUST	20	Present continuously or for long period	II	1D	Electrical apparatus not allowed		
	21	Occur in normal operation occasionally	II	2D	Ex tb 'protection by enclosure t'	IIIC, IIIB, IIIA	IP6X
	22	Rarely occur in normal operation and for short period	II	3D	Ex tc 'protection by enclosure t'	IIIB, IIIA	IP5X

1. Group II: comprises equipment intended for use in other places likely to become endangered by explosive atmospheres (surface plants different from mines).

2. Group II is sub-divided into 3 categories:

Category 1: very high level of protection

Category 2: high level of protection

Category 3: normal level of protection

G explosive atmosphere consisting of a mixture with air and flammable substances in the form of gas, vapour or mist
D explosive atmosphere in the form of a cloud of combustible dust in air

3. Orange1 motors J-K series can have the following types of protection:

Ex eb Increased safety (GAS)

Ex ec Non-sparking (GAS)

Ex tb, Ex tc protection by enclosure 'tD' (DUST)

4.	GAS group	IIC	Hydrogen, Acetylene, carbon disulfide
		IIB	Diethyl ether, Ethylene etc.
		IIA	Propane, Butane, pentane, natural gas etc.
DUST group	IIIC	Conductive dust	
	IIIB	Non-conductive dust	
	IIIA	Combustible fibers	

5. (GAS) In function of their maximum surface temperature the motors are classified in a temperature class.

6. (DUST) The surface temperature must be less or equal than the minimum value between Tmax1 e Tmax2 where:
 $T_{max1} = 2/3 \cdot T_{cl}$ with T_{cl} ignition temperature in °C of the dust cloud.

Potential Explosive Atmospheres - ATEX

Increased Safety

Increased safety design, Ex eb

The design of this motor type prevents the occurrence of sparks, arcs or hot spots in service (including starting and locked rotor situation), that could reach the self-ignition temperature of the surrounding, potentially explosive atmosphere, in all inner and outer parts of the machine. This is ensured by applying constructional or dimensional provisions that mainly concern:

- specified minimum values for creepage distances and clearances
- use of tracking-proof isolating materials
- suppression of sharp angles where static electrical loads could build-up
- ensuring electrical and mechanical assemblies are tightly secured
- minimum backlash values between stationary and rotating parts (e.g., air gap, ventilation, etc.)
- temperature
- rise limits, taking into account locked rotor and normal operation under the most adverse thermal conditions (in case of the worst voltage conditions).

Thermal protection

1. When intended for use with a current-dependent device to protect against exceeding the limiting temperature, the starting current ratio I_A/I_N and the time t_E shall be determined and marked (t_E shall not be less than 5sec while I_A/I_N shall not exceed 10). So to prevent from exceeding the limit temperature the protection devices must trip within the time t_E .
2. When intended for use with winding temperature sensors associated with protective devices to protect against the occurrence of non-permissible temperatures, the starting current ratio I_A/I_N shall be determined and marked. Time t_E is not required to be determined and marked.

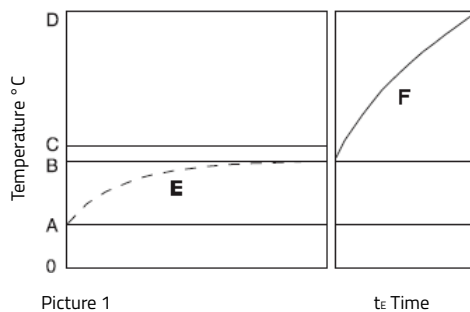

- O = temp. 0°C
- A = Max. ambient temp.
- B = Temp. at rated load and worst voltage conditions
- C = Max temp. as permitted by the insulation class
- D = Max limit temp.
- E = Temperature-rise curve of motor at rated output and at worst voltage conditions
- F = Temp. rise curve under stalled rotor conditions
- t_E = stalled rotor time

Non-sparking design, Ex eb and Ex ec

This type of protection is allowed to be used in the hazardous area corresponding to zone 2. This design is also known as 'Non-sparking' type as the motor must be designed in such a way that no sparks can occur in normal operation, used within the ratings specified by the manufacturer, which excludes thermal requirements due to starting or accidental stalling.

Protection by enclosures "t"

This protection prevents any explosion transmission of dust because: the IP protection avoid to the dust to go inside the moto, the maximum surface temperature outside the motor must not exceed the limit temperature, no sparks must occur outside the motor enclosure.

Potential Explosive Atmospheres - ATEX

Increased Safety



GAS - MAIN INFLAMMABLE SUBSTANCES

Inflammable substance	Group of GAS	temperature of ignition	Temp. Class	Inflammable substance	Group of GAS	temperature of ignition	Temp. Class
2-Methylpentane	IIA	300	T2	Ethyl formate	IIA	440	T2
Amyl acetate	IIA	360	T2	Methyl formate	IIA	450	T1
Butyl-n acetate	IIA	425	T2	Natural gas	IIA	482	T1
Ethyl acetate	IIA	426	T2	Isobutane	IIA	460	T1
Isobutyl acetate	IIA	420	T2	Isoheptane	IIA	220	T3
Methyl acetate	IIA	502	T1	Isohexane	IIA	264	T3
Propil acetate	IIA	430	T2	Isooctane	IIA	410	T2
Vinyl acetate	IIA	425	T2	Isoprene	IIA	220	T3
Acetone	IIA	465	T1	Methane	IIA	537	T1
Methanol	IIA	464	T1	Methylcyclopentane	IIA	258	T3
Brome thane	IIA	511	T1	Methylamine	IIA	430	T2
Butane	IIA	287	T3	Methylmetacrylate	IIA	430	T2
Butane - 1	IIA	384	T2	Paraldehyde	IIA	239	T3
Butane - 2	IIA	325	T2	Pentane	IIA	258	T3
Cycloexano	IIA	259	T3	Pyridine	IIA	483	T1
Cycloexanol	IIA	300	T2	Propane	IIA	470	T1
Cyclohexanone	IIA	419	T2	Propylamine	IIA	318	T2
Cyclohexene	IIA	244	T3	Propylbenzene	IIA	450	T1
Cyclopropane	IIA	498	T1	Propylene	IIA	455	T1
Cymene (p)	IIA	436	T2	Styrene	IIA	490	T1
Chloro-benzene	IIA	637	T1	Toluene	IIA	480	T1
Acetyl chloride	IIA	390	T2	m-Xylene	IIA	522	T1
Allyl chloride	IIA	390	T2	o-Xylene	IIA	464	T1
Chlorbutane	IIA	240	T3	p-Xylene	IIA	528	T1
Chloroethane	IIA	495	T1	1,2 Butadiene	IIB	430	T2
Vinyl chloride	IIA	472	T1	1,3 Butadiene	IIB	430	T2
Dichlorobenzene	IIA	648	T1	Dioxane	IIB	245	T3
Dichloroethylene 1,1	IIA	570	T1	Diethyl ether	IIB	160	T4
Dichloroethylene 1,2	IIA	441	T2	Ethyl vinyl ether	IIB	200	T3
Diethylamine	IIA	312	T2	Methyl vinyl ether	IIB	350	T2
Dimethylamine	IIA	400	T2	Acrylate ethyl	IIB	350	T2
Dimethylaniline	IIA	371	T2	Ethylene	IIB	425	T2
Dimethylbutane 2,3	IIA	405	T2	LPG	IIB	365	T2
Dimethylpentane 2,3	IIA	330	T2	Sulphurated Hydrogen	IIB	260	T3
Heptane	IIA	215	T3	Methylacrylate	IIB	415	T2
Hexane	IIA	233	T3	Carbon monoxide	IIB	605	T1
Heptane	IIA	515	T1	Ethylene oxide	IIB	435	T2
Ethylacetoacetate	IIA	350	T2	Propylene oxide	IIB	430	T2
Ethylamine	IIA	385	T2	Acetylene	IIC	305	T2
Ethylmercaptane	IIA	295	T3	Hydrogen	IIC	500	T1
Butyl formate	IIA	320	T2	Carbon disulfide	IIC	95	T6

DUST - MAIN INFLAMMABLE SUBSTANCES

	Substance	Medium largeness particles (mm)	LEL (g/m3)	Cloud ignition temperature Tci (°C)	Layer 5mm thick ignition temperature TI (°C)
Metals, alloys	Aluminium	10	60	560	430
	Bronze	18	750	390	260
	Iron	12	500	580	>450
	Graphite	7	30	600	680
	Lamp-black (carbon black)	13	15	620	435
	Sulphur	20	30	280	260
Wood, products of wood, fibres	Paper		100	620	370
	Cellulose (93% sweet wood, 6% hard wood)	14	15	420	335
	wood flour	60		470	305
	Wood (50% pear tree and 50% kernel)	35	100	500	340
	Wood (beech)	61		490	310
	Wood (pear tree)	27	100	500	320
	Sawdust of wood	65		470	290
	Cork	42	30	470	300
Agricultural products	Cacao	3	125	460-540	245
	Coffee	10	25	360	450
	Cereals (mixed powders)	37	125	510	300
	Wheat flour	56-125	60	480	>450
	Soy flour	20	200	620	280
	Gelatine	65	60	560	>450
	Wheat		100	470	220
	Dry milk	165	60	460	330
	Milk sugar	22	60-125	450	>450
	Rye			415-470	325
	Buttermilk	400		450	420
	Tobacco		60	485	290
	Black tea	76	125	510	300
Sugar	32	30	360	>450	
Powdered sugar	17	60	350	>450	

Potential Explosive Atmospheres - ATEX

Increased Safety

3. General informations

3.1 Range of motors

Ex Elprom motors are manufactured in compliance with all the European standards concerning equipment and protective systems for potentially explosive atmosphere in compliance with the European Directive ATEX 94/9/CE (better known as ATEX). Here below in the table we show you the range of motors for each type of protection.

In the following pages we will speak about testing and certificates, main features of these motors and options that is possible to have depending always on the type of protection.

RANGE OF MOTORS

Version	Type	Frame size	Pole N°	Output range (kW)	Type of Protection	Temperature class Surface temperature	ATEX Category	ATEX Zone					
GAS	Increased safety	3-ph 1 speed	56-160	2	0,09 – 18,5	Ex eb	T3 Ta –40°C +45°C	2G	1-2				
			56-160	4	0,06 – 15								
			63-160	6	0,09 – 11								
			71-160	8	0,09 – 7,5								
	1-ph 1 speed (2)	56-112	2	0,09 – 4									
		56-112	4	0,06 – 3									
	Non Sparking	3-ph 1 speed	56-160	2	0,09 – 18,5					Ex ec	T3 Ta –20°C +40°C T4 Ta –20°C +40°C	3G	2
			56-160	4	0,06 – 15								
			63-160	6	0,09 – 11								
			71-160	8	0,09 – 7,5								
1-ph 1 speed (2)		56-112	2	0,09 – 4									
		56-112	4	0,06 – 3									
DUST	Increased Safety Dust ignition protection (conductive Dust)	3-ph 1 speed	56-160	2	0,09 – 18,5	Ex tb IIIC	T125°C Ta –40°C +45°C	2D	21-22				
			56-160	4	0,06 – 15								
			63-160	6	0,09 – 11								
			71-160	8	0,09 – 7,5								
	1-ph 1 speed (2)	56-112	2	0,09 – 4									
		56-112	4	0,06 – 3									
	Non Sparking Dust ignition protection (non- conductive Dust)	3-ph 1 speed	56-160	2	0,09 – 18,5					Ex tc IIIB	T125°C Ta –20°C +40°C	3D	22
			56-160	4	0,06 – 15								
			63-160	6	0,09 – 11								
			71-160	8	0,09 – 7,5								
1-ph 1 speed (2)		56-112	2	0,09 – 4									
		56-112	4	0,06 – 3									

1- The capacitor of the single phase motors is put inside a special Ex d cylindrical enclosure fitted on the motor itself. Otherwise it must be placed in a safe area.

3.2 Testing and certificates

Motors for hazardous areas have to be officially approved by a recognized test organization, authorized to issue test certificates, to ensure compliance with standards for this type of equipment.

Motors are defined and classified according to the categories and protection type which are defined in the corresponding standards. Depending on the nature of the atmosphere, it is the responsibility of the user to determine which group and which maximum surface temperature should be specified for the motor installation.

The Ex motors built by Orange1 Electric Motors are manufactured in compliance with all the European standards concerning equipments and protective systems for explosive atmosphere as requested by the European Directive 2014/34/CE (better known as ATEX Directive).

The motors have been tested by a Notified Laboratory which released:

- EC Type Certificate
- Product Quality assurance Notification

It means that all the Ex motors are manufactured in compliance with the technical drawings and documents approved by the Notified Body after testing the motors (performing type test as written in the EN standards) and the production of such motors follows all the procedures requested by the Directive.

Every year the Production of Ex motors is valuated by a Notified body to verify that all the procedures are constantly respected. Each motor or batch of motors will be despatched together with the following documents:

- EC Declaration of Conformity
- Installation manual and safety instructions where are written all the indication regarding the installations of the motors and the important instructions regarding the type/s of protection of the motors.

As explained before Elprom produces different Ex motors that can be installed in different Ex areas.

3.3 Main features

ELPROM Ex electric motors are built and tested in comply with all the EN/IEC standards and also comply with the main European Directives. First of all the directive 94/9/EC (ATEX as already explained), 89/336/EC (EMC Electro Magnetic Compatibility), 98/37EC (Machinery Directive), 2002/95/EC (RoHS).

All the motors are asynchronous with squirrel cage rotor, wound stator, closed and externally ventilated in comply with EN 60034-6 (IC 411).

Supply voltage 230/400 V \pm 5% Δ /Y (56 - 112), 400/690 V \pm 5% Δ /Y (132 - 160) and frequency 50 Hz \pm 2% (EN 60034-1).

The power ratings and the dimensions of the motors comply with EN 50347 and IEC 60072-1, the mounting arrangements B3, B5, B14 comply with EN 60034-7.

All the geometrical dimensions are unified following the tables UNEL 13113-71; 13117-71; 13118- 7; IEC 60072-1.

The IP degrees of protection of the motors comply with EN 60034-5. It depends on the type of protection as follow:

Ex eb IP55 (they have to be at least IP54 as requested by the standard EN 60079-7)

- Ex ec IP55 (they have to be at least IP54 as requested by the standard EN 60079-15)
- Ex tc IIIB IP55 for non-conductive dust (the standard EN 60241-1 states that it have to be at least IP5X)
- Ex tb IIIC IP65 (or IP66) for conductive dust (the standard EN 60241-1 states that it have to be at least IP6X)

Insulation class - All the motors have an insulation class F in compliance with EN 60034-1.

The bearings - are high-quality single raw deep grooves ball bearings, preloaded by a wave spring.

Duty - The motors are normally built for S1 duty, otherwise S3 duty can be done on request after performing the heating tests.

Single-phase motors - Capacitor placed in a safe Ex d cylindrical box fitted to the motor.

Windings - Made using enamelled copper wires are insulated by two layers (insulation class H). They are painted with another layer of varnish and after this placed in an oven so to dry it. The maximum ambient temperature is 40 °C. It is also possible to tropicalize the windings using special additional varnish with high hygroscopic characteristics so to be used in places with an humidity >60% (see options)

Rotors - Die-cast aluminium squirrel cage aluminium alloy slots.

The shafts - of the motors and the keys-shaft comply IEC 60072-1. Special shaft are made on request (see options).

Frame - (in compliance with IEC 60072-1) Die-cast aluminium with high mechanical strength, with a good thermal conductivity and light weight. The feet can be mounted on the motor frame in 3 different positions, in the bottom or on right and left side.

Terminal box - The terminal box in case of motor B3, is normally on the top of the motor. As the feet can mounted also on the sides of the frame it is possible to have the terminal box on both the sides of the motor too.

Flanges and shields - (in compliance with IEC 60072-1) Die-cast aluminium, with dimensions as per standard IEC 60072-1, or with special shapes on request (see options).

Ventilation - (in compliance with EN 60034-6) Self-ventilated motors IC 411. Depending on the type of protection the fan can be in plastic (Ex eb, Ex ec, Ex tc) or in aluminium (Ex tb).

Fan cover - Zinc-plated steel sheet.

Noise - (in compliance with EN 60034-9)

Increased Safety

3.4 Main options

Axially locked shaft (IEC63 ... IEC160)

Motors with a locked bearing on the front shield using an elastic metal ring. This solution is necessary in case of alternative axial stress (ie. Bevel gear pinion with alternative load or motion, frequent start-up under load or with high inertia) so to create axial movement of the shaft and bumps on the bearings.

Low temperatures motors (-40 °C) (IEC56 ... IEC160)

They have to be fitted with special bearing, metallic fan, metallic cable gland and plugs or made of special plastic materials. In these cases, if there is a risk of condensation, it is better to fit the motors with "anti-condensation heaters" or drain holes.

Condensation drain holes

These are motors with proper drain holes, for the discharge of condensed water that forms in specific climatic conditions. If necessary motors with these characteristics is appropriate to indicate not only the mounting type but also the position of the motor during the final use, in order to determine the proper location of the drain holes.

The motors are delivered with the holes sealed by a plug.

Tropicalization of windings

If the motors are installed outdoors or in high humidity areas, the windings may be tropicalized with a special varnish that has high hygroscopic characteristics in order to protect the insulation materials by the condensation. This protection avoid the reduction of the insulation properties of the windings.

Special voltages and frequencies

The standard three phase motors are produced at the following nominal voltages and frequencies:

230 / 400 V , 50 Hz - up to 4 kW

400 / 690 V , 50 Hz - more than 4 kW

The motors can run at a different nominal voltage with a tolerance of +/- 5%

On customer request, we can produce motors with special voltage and frequency.

Special shafts

On customer request, it is possible to supply motors with special shaft as customer drawing. Send a drawing to our Technical Department for a feasibility study. It is possible to supply motors with shaft material different from the standard (C40), using Stainless Steel or others, with standard dimensions or special as customer drawing.

Special flanges

In some applications it is necessary to use special flanges on customer design to optimize the assembling or reduce the costs avoiding the use of adaptors. It is possible to send to our Technical Department a request with drawings and material specifications. Shortly will be made a cost evaluation of the parts and the tools.

Mating tolerances under "accuracy" rating to UNEL 13501-69 (DIN 42955) (special IM B5, IM B14, IM B5)

For application that need particularly small tolerances between shaft and shields due to particular couplings (ie.: gears-motors).

Rain fan cover

For outdoor applications, vertical mounting, DE shaft down (V5, V1, V18) it is suggested to assemble a special cowl with a rain cover. It is available for all the frame sizes.

Thermistors (PTC Positive Temperature Coefficient)

They are fitted inside the windings in number of 3 with a series connection to be connected to an appropriate tripping device that cut off the motors supply in case the winding reach the thermal probe limit temperature. On request will be available protectors with different temperature setting.

Painting (against corrosion)

In case of motors 2G, the paint thickness will follow the table in standard EN 60079-0 table 8, thus:

Group IIA IIB : maximum thickness 2mm

Group IIC : maximum thickness 0,2mm

Motors referred to categories Ex eb 2GD and 2D are not painted.

Potential Explosive Atmospheres - ATEX

Increased Safety and Non Sparking



MOTOR TYPE (Increased Safety)	
Motors Efficiency IE2 - IE3	
JH	Three phase Ex eb IE2 IE3
KH	Single phase Ex eb IE2

SHAFT HEIGHT
56, 63, 71, 80, 90, 100, 112, 132, 160, 180

MOTOR TYPE	
Motors Efficiency IE2 - IE3	
A	63, 71, 80, 90, 100, 112, 132, 160, 180
B	56, 63, 71, 80, 100, 112, 132, 160
C	80, 112
D	90, 132, 160, 180
E	132, 160
S	132
Z	71, 80

MOTOR TYPE	
2, 4, 6, 8	Three phase motors

MOUNTING		
B3 - V6		H
V5		3
B5 - V3		F
V1		G
B14 - V19		Q
V18		A
B35 - V36		X
V15		9
B34 - V69		W
V58		5

VOLTAGE	
For double voltage is written the lower voltage (ex. 230 for 230/400)	

FREQUENCY		
5		50 Hz
6		60 Hz
7		50/60 Hz

PROTECTION AND TEMPERATURE CLASS	
T	II 2G Ex eb IIC T3 Gb
U	II 2GD Ex eb IIC T3 Gb Ex tb IIIC T125°C Db

THERMAL PROTECTOR	
4	No thermal protection
G	PTC TRIPLE 150°C

AMBIENT			
Code	Tmin	Tmax	Note
5	-20	45	-
6	-40	40	Only MEC 160 2 Poli 2GD
7	-20	40	Only MEC 160 2 Poli 2G
8	-40	45	-

MOTOR TYPE (Non Sparking)	
Motors Efficiency IE2 - IE3	
JK	Three phase Ex ec IE2 IE3
KK	Single phase Ex ec IE2

SHAFT HEIGHT
56, 63, 71, 80, 90, 100, 112, 132, 160, 180

MOTOR TYPE	
Motors Efficiency IE2 - IE3	
A	63, 71, 80, 90, 100, 112, 132, 160, 180
B	56, 63, 71, 80, 100, 112, 132, 160
C	80, 112
D	90, 132, 160, 180
E	132, 160
S	132
Z	71, 80

MOTOR TYPE	
2, 4, 6, 8	Three phase motors

MOUNTING		
B3 - V6		H
V5		3
B5 - V3		F
V1		G
B14 - V19		Q
V18		A
B35 - V36		X
V15		9
B34 - V69		W
V58		5

VOLTAGE	
For double voltage is written the lower voltage (ex. 230 for 230/400)	

FREQUENCY		
5		50 Hz
6		60 Hz
7		50/60 Hz

PROTECTION AND TEMPERATURE CLASS	
U	II 3GD Ex ec IIC T3 Gc Ex tc IIIB T125°C Dc
V	II 3GD Ex ec IIC T4 Gc Ex tc IIIB T125°C Dc

THERMAL PROTECTOR	
4	No thermal protection
U	PTC TRIPLE 130°C
G	PTC TRIPLE 150°C

AMBIENT		
Code	Tmin	Tmax
6	-20	40

Potential Explosive Atmospheres - ATEX

Increased Safety

4. Terminal box, cable entries and connections

As the feet are can be mounted on the frame (motor size 63 – 160) it is possible to fix them in 3 different positions so to have the possibility to have the terminal box on the top or on the right and left sides of the motor (see picture 1) At the same time the terminal box can be mounted on the motor so to have the cable entries where it is necessary. So the cable entries can be in the four different positions (see picture 2).

POSITION OF TERMINAL BOX AND CABLE ENTRIES

Motor size	Cable glands	
	Main	Aux
56	M20	M20
63	M20	M20
71	M20	M20
80	M20	M20
90	M20	M20
100	M20	M20
112	M20	M20
132	M25	M20
160	M32	M20

Motors Ex eb and Ex ec

The increased safety motors and no sparking motors are built with a special terminal board and the cable glands shall be certified in compliance with EN 60079-7 for the motor “Ex eb” and with EN 60079-15 for the motors “Ex ec”

In the picture you can see the special terminal board (complying with EN 60079-7) used for these motors and the type of connection requested so to satisfy both the standards EN 60079-7 and EN 60079-15. In case of motor fitted with thermal protection heaters etc. the wires of these devices will be connected when possible to the auxiliary pins of a 8 pins terminal board. If it is not possible they must be connected to the cable welding the wires of the device to the cable wires and insulating them using a thermic sheath.

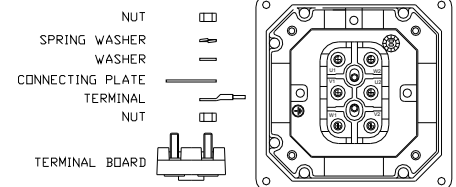

Motors Ex tb and Ex tc

For these type of motors there is no need of a special terminal board and the cable glands shall be certified in compliance with EN 61241-0 and 61241-1.

Motors without terminal box complete of cable

To reduce the total height of the motor, it is possible to have the motor without terminal box and complete of supply cable. The cable outlet can be on the top or on the sides.

WIRING DIAGRAMS

<p>3-PH 1 SPEED</p> <p>Delta connection Star connection</p> <p>Lower Voltage Higher Voltage</p>	<p>3-PH 1 SPEED (9 WIRES)</p> <p>Lower voltage Higher voltage</p>
<p>1-PH – RUN CAPACITOR (4 WIRES)</p> <p>Clockwise rotation Counter clockwise rotation (SHAFT SIDE VIEW)</p>	<p>1-PH – RUN CAPACITOR (3 WIRES)</p> <p>Clockwise rotation Counter clockwise rotation (SHAFT SIDE VIEW)</p>

5. Mechanical Characteristics

MOUNTING ARRANGEMENTS

Foot mounted					
IM 1001 (IM B3)	IM 1051 (IM B6)	IM 1061 (IM B7)	IM 1071 (IM B8)	M 1011 (IM V5)	IM 1031 (IM V6)
Flange mounted					
IM 3001 (IM B5)	IM 3011 (IM V1)	IM 3031 (IM V3)	IM 3601 (IM B14)	IM 3611 (IM V18)	IM 3631 (IM V19)
Foot-flange mounted					
IM 2001 (IM B35)	IM 2011 (IM V15)	IM 2031 (IM V36)	IM 2101 (IM B34)	IM 2111 (IM V58)	IM 2131 (IM V69)

MAIN COMPONENTS

Component	Material	Note
Frame	Aluminium	Removable feet (aluminium)
End- shields	Aluminium	
Flange B5	Aluminium	
Flange B14	Aluminium	
Terminal box	Aluminium	
Shaft	Steel C40	
Rotor	Magnetic lamination die-cast aluminium	
Stator	Magnetic lamination	
Windings	Enamelled copper wires (two layers)	
V-Ring	NBR rubber	Special material: VITON
Bearings	Deep groove ball bearings	See below
Fan	Plastic (Ex e, Ex nA), Aluminium or antistatic plastic (Ex tD A21)	

BEARING AND SEALS

Motor Size	Bearings		Seals	
	Drive End	Non Drive End	Drive End	Non Drive End
56	6201-ZZ	6201-ZZ	v-Ring Ø12	v-Ring Ø12
63	6202-ZZ	6202-ZZ	v-Ring Ø14	v-Ring Ø14
71	6202-ZZ	6202-ZZ	v-Ring Ø14	v-Ring Ø14
80	6204-ZZ	6204-ZZ	v-Ring Ø20	v-Ring Ø20
90	6205-ZZ	6205-ZZ	v-Ring Ø25	v-Ring Ø25
100	6206-ZZ	6206-ZZ	v-Ring Ø30	v-Ring Ø30
112	6206-ZZ	6206-ZZ	v-Ring Ø30	v-Ring Ø30
132	6208-ZZ	6208-ZZ	v-Ring Ø40	v-Ring Ø40
160	6209-ZZ	6209-ZZ	v-Ring Ø45	v-Ring Ø30

The motors are normally fitted with permanently greased bearings of type 2Z, lubricated with a special grease G-15 and have a service max temperature of 150°C.

The bearing life time for aluminium motors is approximately (depending on application and load conditions):

- 2 and 2/4 pole motors, 10 000 - 20 000 duty hours

- 4 to 8 pole motors, 20 000 - 40 000 duty hours Both on drive end and non-drive end are mounted V-ring seals in order to have the IP66 protection.

Both on drive end and non-drive end are mounted V-ring seals in order to have the IP66 protection.

- Motors Ex eb: IP55 (should be at least IP54 in compliance with EN 60079-7)

- Motors Ex ec: IP55 (should be at least IP54 in compliance with EN 60079-15)

- Motors Ex tc IIIIB: IP55 (should at least IP6X in compliance with EN 61241-1 - conductive dust)

- Motors Ex tb IIIC: IP65 (should at least IP6X in compliance with EN 61241-1 - non conductive dust)

5.1 Radial and axial forces on the shaft end

5.1.1 Permissible radial load

Here we show the permissible radial load (FR) that can be applied to three different positions (X0, L/2 and L where L is the length of the shaft axis) on the shaft-end, supposing motors running at 50Hz and bearings life time at least 20,000 hours for 2 poles motors and 40,000 hours for 4-6-8 poles. For service on 60Hz reduce values by 10%. Take the higher speed as reference for double pole motors.

This the formula to calculate F_R in a point of the shaft with generic position X: $F_R = F_{X0} - (F_{X0} - F_L)X/L$

PERMISSIBLE RADIAL LOAD													
Motor size	Shaft length	3000 rpm			1500 rpm			1000 rpm			750 rpm		
	L (mm)	X0	L/2	L	X0	L/2	L	X0	L/2	L	X0	L/2	L
56	20	350	325	300	350	325	300	-	-	-	-	-	-
63	23	390	365	340	390	365	340	450	420	390	-	-	-
71	30	490	450	410	490	450	410	560	515	470	610	565	520
80	40	650	590	530	650	590	530	750	680	610	820	745	670
90S	50	720	645	570	720	645	570	820	735	650	910	815	720
90L	50	720	650	580	720	650	580	830	750	670	920	830	740
100	60	1020	920	820	1020	920	820	1160	1045	930	1290	1165	1040
112	60	1410	1280	1150	1410	1280	1150	1610	1455	1300	1780	1610	1440
132	80	1520	1370	1220	1520	1370	1220	1540	1465	1390	1910	1720	1530
160	110	2750	2455	2160	2750	2455	2160	2750	2600	2450	3430	3055	2680

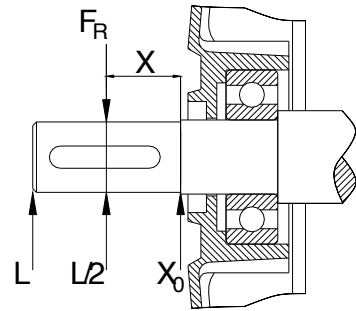

For Belt drive applications the maximum radial load FR is given by:

$F_R = \text{maximum radial load [N]} = (P + F)$ where:

- P = pulley weight [N]
- F = belt tension [N] = $(2 \cdot K \cdot M)/D$ where:
- K = belt tension factor (K = 3 for normal flat belt without idler pulley; K = 2,2 for V-belt; K = 2 for normal flat belt with idler pulley)
- D = pulley diameter [m]
- M = torque [Nm] = $9550 \cdot P/n$ where:
- P = output [kW]
- n = speed in [1/min]

5.1.2 Permissible axial load (with additional radial load applied at the end of the shaft)

In the table below we show the additional axial load (FA) allowable if the maximum radial load (FR) is applied on the shaft. The lower is radial load, the bigger is allowable axial load.

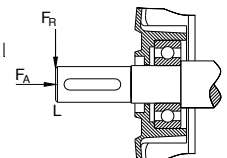

Axial load calculations have been carried out in three different foot mounting operating conditions: horizontal (B3), vertical shaft-down (V5) and vertical shaft-up (V6), supposing the case of thrust T or pull P force.

PERMISSIBLE AXIAL LOAD (WITH MAXIMUM RADIAL LOAD APPLIED ON L)																								
Motor size	IM 1001 (IM B3)								M 1011 (IM V5)								IM 1031 (IM V6)							
	Thrust				Pull				Thrust				Pull				Thrust		Pull					
	2 poles		4 poles		6 poles		8 poles		2 poles		4 poles		6 poles		8 poles		2 poles		4 poles		6 poles		8 poles	
	T	P	T	P	T	P	T	P	T	P	T	P	T	P	T	P	T	P	T	P	T	P		
56	220	100	220	100	-	-	-	-	230	90	230	90	-	-	-	-	220	100	220	100	-	-	-	-
63	240	110	240	110	280	120	290	120	250	100	250	100	290	110	290	110	230	120	130	120	270	130	280	130
71	300	140	300	130	350	160	380	170	320	120	320	110	370	140	400	150	280	160	280	150	330	180	360	190
80	400	190	400	180	460	210	510	240	430	160	440	140	500	170	550	200	370	220	360	220	420	250	470	280
90S	430	200	430	210	500	230	550	260	460	170	470	170	540	190	590	220	400	230	390	250	460	270	510	300
90L	440	200	440	200	510	240	560	260	480	160	490	150	560	190	610	210	400	240	390	250	460	290	510	310
100	620	290	610	290	710	330	780	370	680	230	690	210	790	250	860	290	560	350	530	370	630	410	700	450
112	860	400	850	400	980	460	1080	500	950	320	960	290	1090	350	1190	390	780	480	740	510	870	570	970	610
132	920	430	920	430	1050	500	1170	550	1080	270	1130	220	1260	290	1380	340	760	590	710	640	840	710	960	760
160	1680	800	1670	800	1920	920	2120	1010	1940	540	1970	500	2220	620	2420	710	1420	1060	1370	1100	1620	1220	1730	1370

Potential Explosive Atmospheres - ATEX

Increased Safety



6. Electrical data

6.1 Motors for ATEX Zones 1, 21 (Increased safety 'Ex eb', protection by enclosure 'tb' IIIC)

6.1.1 Three-phase motors, 1 speed

Three Phase Motors - IE2 and IE3 Efficiency Level

Single speed. 3000rpm. 2poles. 400V. 50Hz. S1 Thermal class F; temperature rise class B

Eff. Class	Series Type	Rated Power		Rated current at 400V	Rated speed	Rated Torque	Efficiency			Power factor	Starting current / Rated current	Starting torque / Rated torque	Break-down torque / Rated torque	t _ε (s) - max		Moment of inertia	Weight
		P _n		I _n	n	M _n	η	η	η	COS φ	I _s /I _n	M _s /M _n	M _b /M _n	T3	T3	j	kg
		kW	HP	A	min ⁻¹	Nm	% full load	% 3/4 load	% 1/2 load					40°	45°	10 ⁻³ kgm ²	
IE2	JH 56M B2	0,12	0,16	0,50	2790	0,41	55,1	50,9	42,8	0,600	3,9	3,3	2,9	NA	21	0,183	4,4
IE2	JH 63M A2	0,18	0,25	0,58	2800	0,61	64,0	61,2	54,4	0,710	3,9	3,1	3,0	NA	21	0,183	4,4
IE2	JH 63M B2	0,25	0,35	0,75	2830	0,81	65,4	62,6	55,8	0,680	4,7	3,2	3,3	NA	21	0,214	4,8
IE2	JH 71M A2	0,37	0,50	1,13	2890	1,22	69,5	63,5	55,4	0,680	6,7	3,6	3,8	NA	10	0,451	6,5
IE2	JH 71M B2	0,55	0,75	1,49	2890	1,82	74,1	71,6	64,8	0,720	6,8	3,7	3,9	NA	10	0,542	7,6
IE3	JH 80M A2	0,75	1,0	1,59	2885	2,49	84,2	84,8	83,3	0,810	7,2	3,2	3,5	NA	11	1,037	9,8
IE3	JH 80M B2	1,10	1,5	2,50	2870	3,70	83,1	83,9	82,7	0,770	7,8	3,8	3,6	NA	11	1,201	11,9
IE3	JH 90S A2	1,5	2,0	3,16	2885	5,00	84,8	85,4	84,1	0,790	7,9	3,6	3,7	NA	9	1,591	13,5
IE3	JH 90L D2	2,2	3,0	4,84	2895	7,28	86,2	86,3	84,4	0,760	7,9	4,4	4,6	NA	9	2,022	16,8
IE3	JH 100L A2	3,00	4,0	5,72	2885	9,95	87,9	88,9	88,5	0,860	8,6	4,0	3,8	NA	7	3,702	18,3
IE2	JH 112M A2	4,00	5,5	7,50	2865	13,33	85,8	88,8	88,9	0,900	8,5	3,0	3,2	NA	6	6,303	31,5
IE3	JH 132S A2	5,5	7,5	10,58	2935	17,90	89,2	88,8	87,2	0,840	7,7	3,2	4,6	NA	7	12,081	43,7
IE3	JH 132S B2	7,5	10,0	14,20	2935	24,41	90,1	89,7	88,5	0,850	7,9	2,8	3,7	NA	7	14,739	46,2
IE3	JH 160M A2	11,00	15,0	20,35	2950	35,61	91,4	91,5	90,5	0,850	8,0	2,8	3,5	NA	5	33,698	48
IE2	JH 160M B2	15,00	20,0	29,60	2950	48,60	90,3	90,5	89,6	0,810	9,7	4,4	4,3	5	NA	44,465	97
IE2	JH 160L D2	18,50	25,0	35,30	2950	59,90	90,9	91,4	90,0	0,840	9,9	3,2	3,4	NA	5	52,002	100

Three Phase Motors - IE2 and IE3 Efficiency Level

Single speed. 1500rpm. 4poles. 400V. 50Hz. S1 Thermal class F; temperature rise class B

Eff. Class	Series Type	Rated Power		Rated current at 400V	Rated speed	Rated Torque	Efficiency			Power factor	Starting current / Rated current	Starting torque / Rated torque	Break-down torque / Rated torque	t _ε (s) - max		Moment of inertia	Weight
		P _n		I _n	n	M _n	η	η	η	COS φ	I _s /I _n	M _s /M _n	M _b /M _n	T3	T3	j	kg
		kW	HP	A	min ⁻¹	Nm	% full load	% 3/4 load	% 1/2 load					40°	45°	10 ⁻³ kgm ²	
IE2	JH 63M A4	0,12	0,16	0,49	1390	0,82	60,9	58,6	52,4	0,580	3,3	2,8	2,9	NA	21	0,268	4,6
IE2	JH 63M B4	0,18	0,25	0,57	1340	1,28	64,7	62,4	56,4	0,700	3,3	2,1	2,2	NA	21	0,268	4,6
IE2	JH 71M A4	0,25	0,35	0,79	1430	1,66	69,8	67,1	60,1	0,650	5,3	3,6	4,2	NA	10	0,836	6,5
IE2	JH 71M B4	0,37	0,5	1,08	1420	2,51	72,8	70,5	64,9	0,670	5,4	3,9	3,9	NA	10	1,025	7,8
IE2	JH 80M A4	0,55	0,75	1,32	1440	3,65	77,8	76,7	72,7	0,780	5,9	2,7	3,4	NA	11	2,249	9,6
IE3	JH 80M B4	0,75	1	1,85	1445	4,96	82,5	81,6	78,2	0,708	6,8	3,4	4,1	NA	11	2,644	9,8
IE3	JH 90S A4	1,1	1,5	2,61	1440	7,30	84,1	84,1	81,6	0,724	6,6	2,8	2,8	NA	9	2,979	13,3
IE3	JH 90L D4	1,5	2	3,40	1440	10,00	85,3	84,9	82,9	0,746	6,2	3	3,5	NA	9	4,034	17,5
IE3	JH 100L A4	2,20	3	4,90	1435	14,61	86,7	87,6	87	0,750	7	2,7	3,1	NA	7	6,351	23,6
IE3	JH 112M A4	3	4	6,05	1455	19,70	87,7	88,2	87,4	0,820	7,7	2,7	3,4	NA	6	10,99	32,5
IE3	JH 112M B4	4	5,5	8,25	1455	26,27	88,6	88,7	87,6	0,790	7,3	3,1	3,8	NA	6	11,66	33,8
IE3	JH 132S A4	5,5	7,5	11,77	1455	36,77	89,6	89,9	88,8	0,750	7,4	3,5	3,5	NA	7	25,53	50
IE3	JH 132M D4	7,50	10	15,03	1465	48,86	90,7	91,1	90,4	0,790	8,1	2,7	4	NA	7	36,98	54
IE3	JH 160M D4	11,00	15	21,5	1475	71,23	91,4	91,5	90,5	0,808	5,8	2	2,7	NA	7	73,04	70
IE3	JH 160L E4	15	20	29,54	1474	97,31	92,1	92,2	91,1	0,797	8	3,5	3,3	NA	5	86,71	85

(*) Not available

Potential Explosive Atmospheres - ATEX

Increased Safety



Three Phase Motors - IE2 and IE3 Efficiency Level

Single speed. 1000rpm. 6poles. 400V. 50Hz. S1 Thermal class F; temperature rise class B

Eff. Class	Series Type	Rated Power		Rated current at 400V	Rated speed	Rated Torque	Efficiency			Power factor	Starting current / Rated current	Starting torque / Rated torque	Break-down torque / Rated torque	t _ε (s) - max		Moment of inertia	Weight
		P _n		I _n	n	M _n	η	η	η	COS φ	I _s /I _n	M _s /M _n	M _b /M _n	T3	T3	j	kg
		kW	HP	A	min ⁻¹	Nm	% full load	% 3/4 load	% 1/2 load					40°	45°	10 ⁻³ kgm ²	
IE2	JH 71M Z6	0,12	0,16	0,59	935	1,23	50,6	45,8	37,3	0,580	4,8	2,7	2,9	NA	10	0,360	7,3
IE2	JH 71M A6	0,18	0,25	0,82	925	1,86	56,7	51,9	43,6	0,560	4,8	2,4	2,6	NA	10	1,088	8
IE2	JH 80M Z6	0,25	0,35	0,80	920	2,59	61,8	58,3	50,9	0,730	3,2	2,5	2,6	NA	60	1,590	8,5
IE2	JH 80M A6	0,37	0,5	1,05	930	3,74	72,6	72,3	67,8	0,700	4,2	2,1	2,5	NA	11	2,249	9,3
IE2	JH 80M B6	0,55	0,75	1,50	910	5,77	73,1	71,8	67,2	0,725	5,3	2,6	2,7	NA	11	2,644	10,5
IE3	JH 90L A6	0,75	1	1,96	945	7,58	79,1	78,8	76	0,700	5,7	3,1	3,7	NA	9	5,661	16,7
IE3	JH 100L A6	1,1	1,5	2,70	950	11,06	81	80,8	78,4	0,730	5,9	2,7	3,6	NA	7	10,01	21
IE3	JH 100L B6	1,5	2	3,75	945	15,16	82,5	81,2	78,5	0,700	5,9	2,6	3,4	NA	7	13,04	25,3
IE3	JH 112M A6	2,2	3	5,20	955	21,89	84,3	84,4	83,5	0,720	5,2	1,9	2,7	NA	8	18,63	32,3
IE3	JH 132S A6	3	4	6,32	965	29,69	85,7	86,2	85,4	0,800	6,6	1,8	3,2	NA	7	33,85	44
IE3	JH 132M D6	4	5,5	8,18	965	39,59	86,8	86,9	85,8	0,810	6,9	1,8	3,3	NA	7	45,15	53,2
IE3	JH 160M A6	5,5	7,5	11,40	970	54,14	88,6	88,8	87,5	0,790	7,6	2,9	3,7	NA	5	93,66	90
IE3	JH 160L D6	7,5	10	15,11	970	73,85	89,1	89,4	88,8	0,810	7,9	2,8	4	NA	5	132,81	97

Three Phase Motors - IE2 and IE3 Efficiency Level

Single speed. 750rpm. 8poles. 400V. 50Hz. S1 Thermal class F; temperature rise class B

Eff. Class	Series Type	Rated Power		Rated current at 400V	Rated speed	Rated Torque	Efficiency			Power factor	Starting current / Rated current	Starting torque / Rated torque	Break-down torque / Rated torque	t _ε (s) - max		Moment of inertia	Weight
		P _n		I _n	n	M _n	η	η	η	COS φ	I _s /I _n	M _s /M _n	M _b /M _n	T3	T3	j	kg
		kW	HP	A	min ⁻¹	Nm	% full load	% 3/4 load	% 1/2 load					40°	45°	10 ⁻³ kgm ²	
IE2	JH 71M B8	0,12	0,16	0,72	660	1,74	45,7	42,7	40,7	0,527	2,0	1,6	2	NA	79	1,088	8,5
IE2	JH 80M A8	0,18	0,25	0,86	710	2,42	45,9	42,5	38,5	0,662	2,8	2,2	2,6	NA	23	1,854	10
IE2	JH 80M B8	0,25	0,35	1,18	700	3,41	51	46,7	40,5	0,600	2,3	2,1	2,5	NA	64	2,381	11
IE2	JH 90S A8	0,37	0,5	1,42	665	5,31	56,2	54,9	47,8	0,670	2,2	1,4	1,8	NA	93	2,588	14,5
IE2	JH 90L D8	0,55	0,75	2,07	660	7,96	61,7	58,2	53,4	0,620	2,9	1,7	1,8	NA	93	2,993	16
IE3	JH 100L A8	0,75	1	2,45	714	10,06	75	73,3	67,7	0,585	3,6	2,3	2,5	NA	16	9,251	23
IE3	JH 112M A8	1,1	1,5	2,96	706	14,88	77,7	76,1	71,6	0,689	3,6	2,2	2,4	NA	15	13,97	30
IE3	JH 112M B8	1,5	2	3,96	708	20,23	79,7	78	73,6	0,685	3,8	2,3	2,6	NA	15	18,63	30
IE3	JH 132S A8	2,2	3	5,84	715	29,38	81,9	79,5	74,4	0,664	4,0	2,5	2,9	NA	14	39,40	53
IE3	JH 132M D8	3	4	7,38	715	40,04	83,5	83,1	80,3	0,703	3,8	2,1	2,3	NA	14	50,70	65
IE3	JH 160M A8	4	5,5	9,86	726	52,61	84,8	84,3	81,6	0,691	4,8	1,6	2,4	NA	12	132,75	97
IE3	JH 160L D8	5,5	7,5	13,52	727	72,2	86,3	85,3	82,3	0,681	4,2	1,4	2,5	NA	12	161,24	110

IMPORTANT

In case the motor is equipped with thermal protectors fitted inside the windings, the thermal sensors have to be connected to an appropriate tripping device that cut off the motors supply in case the winding reach the thermal probe limit temperature.

Potential Explosive Atmospheres - ATEX

Increased Safety



6.1.2 Single-phase motors, 1 speed

Single Phase Motors - IE2 Efficiency Level

3000rpm. 2 poles. 230V; 50Hz. S1 - Thermal class F; temperature rise class B; Running Capacitor

Eff. Class	Series Type	Rated Power		Rated current at 230V	Rated speed	Rated Torque	Efficiency			Power factor	Starting current / Rated current	Starting torque / Rated torque	Break-down torque / Rated torque	t _ε (s) - max		Running Capacitor	Moment of inertia	Weight
		P _n		I _n	n	M _n	η	η	η	COS φ	I _s /I _n	M _s /M _n	M _b /M _n	T3	T3	Cr	j	
		kW	HP	A	min ⁻¹	Nm	% full load	% 3/4 load	% 1/2 load					40°	45°	mF	10 ⁻³ kgm ²	
IE2	KH 63MA2	0,18	0,25	1,26	2880	0,60	60,4	53,7	42,7	0,930	4,0	0,5	2,1	10,0	NA	28	0,230	4,1
IE2	KH 63MB2	0,25	0,35	1,68	2720	0,88	66,5	65,2	56,3	0,980	4,0	0,5	1,9	12,5	NA	28	0,230	4,2
IE2	KH 71MA2	0,37	0,50	2,37	2800	1,26	69,5	66,8	56,8	0,970	3,5	0,4	1,7	12,5	NA	28	0,490	6,6
IE2	KH 71MB2	0,55	0,75	3,50	2850	1,85	74,1	70,3	61,6	0,920	4,8	0,7	2,3	20,0	NA	28	0,600	8,0
IE2	KH 80MA2	0,75	1,00	4,45	2880	2,48	77,4	74,7	67,7	0,940	5,4	0,4	2,3	20,0	NA	28	1,201	10,0
IE2	KH 80MB2	1,1	1,50	6,20	2860	3,67	79,6	75,3	68,8	0,970	5,3	0,4	2,0	30,0	NA	28	1,28	11,4
IE2	KH 90LA2	1,5	2,00	8,00	2860	5,00	81,9	80,8	75,7	0,990	5,2	0,4	2,1	40,0	NA	28	1,59	14,8

Single Phase Motors - IE2 Efficiency Level

1500rpm . 4 poles. 230V; 50Hz. S1 - Thermal class F; temperature rise class B; Running Capacitor

Eff. Class	Series Type	Rated Power		Rated current at 230V	Rated speed	Rated Torque	Efficiency			Power factor	Starting current / Rated current	Starting torque / Rated torque	Break-down torque / Rated torque	t _ε (s) - max		Running Capacitor	Moment of inertia	Weight
		P _n		I _n	n	M _n	η	η	η	COS φ	I _s /I _n	M _s /M _n	M _b /M _n	T3	T3	Cr	j	
		kW	HP	A	min ⁻¹	Nm	% full load	% 3/4 load	% 1/2 load					40°	45°	mF	10 ⁻³ kgm ²	
IE2	KH 63MB4	0,12	0,15	1,05	1390	0,82	59,1	52,1	41,5	0,850	2,4	0,5	1,7	5,0	NA	60	0,280	3,9
IE2	KH 71MA4	0,18	0,25	1,22	1420	1,21	64,7	62,1	57,5	0,970	3,6	0,4	1,8	10,0	NA	60	0,970	6,3
IE2	KH 71MB4	0,25	0,35	1,60	1410	1,69	68,5	67,0	62,5	0,980	3,7	0,4	1,8	12,5	NA	60	1,20	7,4
IE2	KH 80MZ4	0,37	0,50	2,20	1430	2,47	72,7	71,2	63,7	0,990	3,2	0,4	1,9	14,0	NA	60	2,25	8,0
IE2	KH 80MA4	0,55	0,75	3,15	1430	3,67	77,1	72,6	67,9	0,990	3,1	0,4	1,9	16,0	NA	60	2,83	10,0
IE2	KH 90SA4	0,75	1,00	4,10	1420	5,04	79,6	76,2	72,4	0,990	3,5	0,3	1,6	30,0	NA	60	3,33	14,4
IE2	KH 90LB4	1,1	1,50	6,00	1410	7,45	81,4	79,0	74,2	0,990	3,4	0,2	1,5	40,0	NA	60	4,10	15,6

Capacitor: is fitted inside a special 'Ex d' cylindrical box and mounted on the motor.

(*) Not available

Potential Explosive Atmospheres - ATEX

Non Sparking



6.2. Motors for ATEX Zones 2, 22 (Non Sparking 'Ex ec', protection by enclosure 'tc' IIIB)

6.2.1 Three-phase motors, 1 speed

Three Phase Motors - IE2 and IE3 Efficiency Level Single speed. 3000rpm. 2poles. 400V. 50Hz. S1 Thermal class F; temperature rise class B

Eff. Class	Series Type	Rated Power		Rated current at 400V	Rated speed	Rated Torque	Efficiency			Power factor	Starting current / Rated current	Starting torque / Rated torque	Break-down torque / Rated torque	Moment of inertia	Weight
		Pn		In	n	Mn	η	η	η	COS φ	Is/In	Ms/Mn	Mb/Mn	j	kg
		kW	HP	A	min ⁻¹	Nm	% full load	% 3/4 load	% 1/2 load						
IE2	JK 56M B2	0,12	0,16	0,50	2790	0,41	55,1	50,9	42,8	0,600	3,9	3,3	2,9	0,183	4,4
IE2	JK 63M A2	0,18	0,25	0,58	2800	0,61	64,0	61,2	54,4	0,710	3,9	3,1	3,0	0,183	4,4
IE2	JK 63M B2	0,25	0,35	0,75	2830	0,81	65,4	62,6	55,8	0,680	4,7	3,2	3,3	0,214	4,8
IE2	JK 71M A2	0,37	0,50	1,13	2890	1,22	69,5	63,5	55,4	0,680	6,7	3,6	3,8	0,451	6,5
IE2	JK 71M B2	0,55	0,75	1,49	2890	1,82	74,1	71,6	64,8	0,720	6,8	3,7	3,9	0,542	7,6
IE3	JK 80M A2	0,75	1,0	1,59	2885	2,49	84,2	84,8	83,3	0,810	7,2	3,2	3,5	1,037	9,8
IE3	JK 80M B2	1,10	1,5	2,50	2870	3,70	83,1	83,9	82,7	0,770	7,8	3,8	3,6	1,201	11,9
IE3	JK 90S A2	1,5	2,0	3,16	2885	5,00	84,8	85,4	84,1	0,790	7,9	3,6	3,7	1,591	13,5
IE3	JK 90L D2	2,2	3,0	4,84	2895	7,28	86,2	86,3	84,4	0,760	7,9	4,4	4,6	2,022	16,8
IE3	JK 100L A2	3,00	4,0	5,72	2885	9,95	87,9	88,9	88,5	0,860	8,6	4,0	3,8	3,702	18,3
IE2	JK 112M A2	4,00	5,5	7,50	2865	13,33	85,8	88,8	88,9	0,900	8,5	3,0	3,2	6,303	31,5
IE3	JK 132S A2	5,5	7,5	10,58	2935	17,90	89,2	88,8	87,2	0,840	7,7	3,2	4,6	12,081	43,7
IE3	JK 132S B2	7,5	10,0	14,20	2935	24,41	90,1	89,7	88,5	0,850	7,9	2,8	3,7	14,739	46,2
IE3	JK 160M A2	11,00	15,0	20,35	2950	35,61	91,4	91,5	90,5	0,850	8,0	2,8	3,5	33,698	48
IE2	JK 160M B2	15,00	20,0	29,60	2950	48,60	90,3	90,5	89,6	0,810	9,7	4,4	4,3	44,465	97
IE2	JK 160L D2	18,50	25,0	35,30	2950	59,90	90,9	91,4	90,0	0,840	9,9	3,2	3,4	52,002	100

Three Phase Motors - IE2 and IE3 Efficiency Level Single speed. 1500rpm. 4poles. 400V. 50Hz. S1 Thermal class F; temperature rise class B

Eff. Class	Series Type	Rated Power		Rated current at 400V	Rated speed	Rated Torque	Efficiency			Power factor	Starting current / Rated current	Starting torque / Rated torque	Break-down torque / Rated torque	Moment of inertia	Weight
		Pn		In	n	Mn	η	η	η	COS φ	Is/In	Ms/Mn	Mb/Mn	j	kg
		kW	HP	A	min ⁻¹	Nm	% full load	% 3/4 load	% 1/2 load						
IE2	JK 63M A4	0,12	0,16	0,49	1390	0,82	60,9	58,6	52,4	0,580	3,3	2,8	2,9	0,268	4,6
IE2	JK 63M B4	0,18	0,25	0,57	1340	1,28	64,7	62,4	56,4	0,700	3,3	2,1	2,2	0,268	4,6
IE2	JK 71M A4	0,25	0,35	0,79	1430	1,66	69,8	67,1	60,1	0,650	5,3	3,6	4,2	0,836	6,5
IE2	JK 71M B4	0,37	0,5	1,08	1420	2,51	72,8	70,5	64,9	0,670	5,4	3,9	3,9	1,025	7,8
IE2	JK 80M A4	0,55	0,75	1,32	1440	3,65	77,8	76,7	72,7	0,780	5,9	2,7	3,4	2,249	9,6
IE3	JK 80M B4	0,75	1	1,85	1445	4,96	82,5	81,6	78,2	0,708	6,8	3,4	4,1	2,644	9,8
IE3	JK 90S A4	1,1	1,5	2,61	1440	7,30	84,1	84,1	81,6	0,724	6,6	2,8	2,8	2,979	13,3
IE3	JK 90L D4	1,5	2	3,40	1440	10,00	85,3	84,9	82,9	0,746	6,2	3	3,5	4,034	17,5
IE3	JK 100L A4	2,20	3	4,90	1435	14,61	86,7	87,6	87	0,750	7	2,7	3,1	6,351	23,6
IE3	JK 112M A4	3	4	6,05	1455	19,70	87,7	88,2	87,4	0,820	7,7	2,7	3,4	10,99	32,5
IE3	JK 112M B4	4	5,5	8,25	1455	26,27	88,6	88,7	87,6	0,790	7,3	3,1	3,8	11,66	33,8
IE3	JK 132S A4	5,5	7,5	11,77	1455	36,77	89,6	89,9	88,8	0,750	7,4	3,5	3,5	25,53	50
IE3	JK 132M D4	7,50	10	15,03	1465	48,86	90,7	91,1	90,4	0,790	8,1	2,7	4	36,98	54
IE3	JK 160M D4	11,00	15	21,5	1475	71,23	91,4	91,5	90,5	0,808	5,8	2	2,7	73,04	70
IE3	JK 160L E4	15	20	29,54	1474	97,31	92,1	92,2	91,1	0,797	8	3,5	3,3	86,71	85

Potential Explosive Atmospheres - ATEX

Non Sparking



Three Phase Motors - IE2 and IE3 Efficiency Level Single speed. 1000rpm. 6poles. 400V. 50Hz. S1 Thermal class F; temperature rise class B

Eff. Class	Series Type	Rated Power		Rated current at 400V	Rated speed	Rated Torque	Efficiency			Power factor	Starting current / Rated current	Starting torque / Rated torque	Break-down torque / Rated torque	Moment of inertia	Weight kg
		Pn		In	n	Mn	η	η	η	COS φ	Is/In	Ms / Mn	Mb/Mn	j	
		kW	HP	A	min ⁻¹	Nm	% full load	% 3/4 load	% 1/2 load					10 ⁻³ kgm ²	
IE2	JK 71M Z6	0,12	0,16	0,59	935	1,23	50,6	45,8	37,3	0,580	4,8	2,7	2,9	0,360	7,3
IE2	JK 71M A6	0,18	0,25	0,82	925	1,86	56,7	51,9	43,6	0,560	4,8	2,4	2,6	1,088	8
IE2	JK 80M Z6	0,25	0,35	0,80	920	2,59	61,8	58,3	50,9	0,730	3,2	2,5	2,6	1,590	8,5
IE2	JK 80M A6	0,37	0,5	1,05	930	3,74	72,6	72,3	67,8	0,700	4,2	2,1	2,5	2,249	9,3
IE2	JK 80M B6	0,55	0,75	1,50	910	5,77	73,1	71,8	67,2	0,725	5,3	2,6	2,7	2,644	10,5
IE3	JK 90L A6	0,75	1	1,96	945	7,58	79,1	78,8	76	0,700	5,7	3,1	3,7	5,661	16,7
IE3	JK 100L A6	1,1	1,5	2,70	950	11,06	81	80,8	78,4	0,730	5,9	2,7	3,6	10,01	21
IE3	JK 100L B6	1,5	2	3,75	945	15,16	82,5	81,2	78,5	0,700	5,9	2,6	3,4	13,04	25,3
IE3	JK 112M A6	2,2	3	5,20	955	21,89	84,3	84,4	83,5	0,720	5,2	1,9	2,7	18,63	32,3
IE3	JK 132S A6	3	4	6,32	965	29,69	85,7	86,2	85,4	0,800	6,6	1,8	3,2	33,85	44
IE3	JK 132M D6	4	5,5	8,18	965	39,59	86,8	86,9	85,8	0,810	6,9	1,8	3,3	45,15	53,2
IE3	JK 160M A6	5,5	7,5	11,40	970	54,14	88,6	88,8	87,5	0,790	7,6	2,9	3,7	93,66	90
IE3	JK 160L D6	7,5	10	15,11	970	73,85	89,1	89,4	88,8	0,810	7,9	2,8	4	132,81	97

Three Phase Motors - IE2 and IE3 Efficiency Level Single speed. 750rpm. 8poles. 400V. 50Hz. S1 Thermal class F; temperature rise class B

Eff. Class	Series Type	Rated Power		Rated current at 400V	Rated speed	Rated Torque	Efficiency			Power factor	Starting current / Rated current	Starting torque / Rated torque	Break-down torque / Rated torque	Moment of inertia	Weight kg
		Pn		In	n	Mn	η	η	η	COS φ	Is/In	Ms / Mn	Mb/Mn	j	
		kW	HP	A	min ⁻¹	Nm	% full load	% 3/4 load	% 1/2 load					10 ⁻³ kgm ²	
IE2	JK 71M B8	0,12	0,16	0,72	660	1,74	45,7	42,7	40,7	0,527	2,0	1,6	2	1,088	8,5
IE2	JK 80M A8	0,18	0,25	0,86	710	2,42	45,9	42,5	38,5	0,662	2,8	2,2	2,6	1,854	10
IE2	JK 80M B8	0,25	0,35	1,18	700	3,41	51	46,7	40,5	0,600	2,3	2,1	2,5	2,381	11
IE2	JK 90S A8	0,37	0,5	1,42	665	5,31	56,2	54,9	47,8	0,670	2,2	1,4	1,8	2,588	14,5
IE2	JK 90L D8	0,55	0,75	2,07	660	7,96	61,7	58,2	53,4	0,620	2,9	1,7	1,8	2,993	16
IE3	JK 100L A8	0,75	1	2,45	714	10,06	75	73,3	67,7	0,585	3,6	2,3	2,5	9,251	23
IE3	JK 112M A8	1,1	1,5	2,96	706	14,88	77,7	76,1	71,6	0,689	3,6	2,2	2,4	13,97	30
IE3	JK 112M B8	1,5	2	3,96	708	20,23	79,7	78	73,6	0,685	3,8	2,3	2,6	18,63	30
IE3	JK 132S A8	2,2	3	5,84	715	29,38	81,9	79,5	74,4	0,664	4,0	2,5	2,9	39,40	53
IE3	JK 132M D8	3	4	7,38	715	40,04	83,5	83,1	80,3	0,703	3,8	2,1	2,3	50,70	65
IE3	JK 160M A8	4	5,5	9,86	726	52,61	84,8	84,3	81,6	0,691	4,8	1,6	2,4	132,75	97
IE3	JK 160L D8	5,5	7,5	13,52	727	72,2	86,3	85,3	82,3	0,681	4,2	1,4	2,5	161,24	110

IMPORTANT

Inverter Duty: even if the 3-ph motors with type of protection 'Ex ec' can be equipped with a thermal protection they can't be used for inverter duty. To be driven by an inverter the motors must be tested with a precise type of inverter and certified for that type.

Potential Explosive Atmospheres - ATEX

Non Sparking

6.2.2 Single-phase motors, 1 speed

Single Phase Motors - IE2 Efficiency Level

3000rpm. 2 poles. 230V; 50Hz. S1 - Thermal class F; temperature rise class B; Running Capacitor

Eff. Class	Series Type	Rated Power		Rated current at 230V	Rated speed	Rated Torque	Efficiency			Power factor	Starting current / Rated current	Starting torque / Rated torque	Break-down torque / Rated torque	Running Capacitor	Moment of inertia	Weight
		Pn		In	n	Mn	η	η	η	COS φ	Is/In	Ms /Mn	Mb/Mn	Cr	j	
		kW	HP	A	min ⁻¹	Nm	% full load	% 3/4 load	% 1/2 load							
IE2	KK 63MA2	0,18	0,25	1,26	2880	0,60	60,4	53,7	42,7	0,930	4,0	0,5	2,1	10,0	0,230	4,1
IE2	KK 63MB2	0,25	0,35	1,68	2720	0,88	66,5	65,2	56,3	0,980	4,0	0,5	1,9	12,5	0,230	4,2
IE2	KK 71MA2	0,37	0,50	2,37	2800	1,26	69,5	66,8	56,8	0,970	3,5	0,4	1,7	12,5	0,490	6,6
IE2	KK 71MB2	0,55	0,75	3,50	2850	1,85	74,1	70,3	61,6	0,920	4,8	0,7	2,3	20,0	0,600	8,0
IE2	KK 80MA2	0,75	1,00	4,45	2880	2,48	77,4	74,7	67,7	0,940	5,4	0,4	2,3	20,0	1,201	10,0
IE2	KK 80MB2	1,1	1,50	6,20	2860	3,67	79,6	75,3	68,8	0,970	5,3	0,4	2,0	30,0	1,28	11,4
IE2	KK 90LA2	1,5	2,00	8,00	2860	5,00	81,9	80,8	75,7	0,990	5,2	0,4	2,1	40,0	1,59	14,8

Single Phase Motors - IE2 Efficiency Level

1500rpm . 4 poles. 230V; 50Hz. S1 - Thermal class F; temperature rise class B; Running Capacitor

Eff. Class	Series Type	Rated Power		Rated current at 230V	Rated speed	Rated Torque	Efficiency			Power factor	Starting current / Rated current	Starting torque / Rated torque	Break-down torque / Rated torque	Running Capacitor	Moment of inertia	Weight
		Pn		In	n	Mn	η	η	η	COS φ	Is/In	Ms /Mn	Mb/Mn	Cr	j	
		kW	HP	A	min ⁻¹	Nm	% full load	% 3/4 load	% 1/2 load							
IE2	KK 63MB4	0,12	0,15	1,05	1390	0,82	59,1	52,1	41,5	0,850	2,4	0,5	1,7	5,0	0,280	3,9
IE2	KK 71MA4	0,18	0,25	1,22	1420	1,21	64,7	62,1	57,5	0,970	3,6	0,4	1,8	10,0	0,970	6,3
IE2	KK 71MB4	0,25	0,35	1,60	1410	1,69	68,5	67,0	62,5	0,980	3,7	0,4	1,8	12,5	1,20	7,4
IE2	KK 80MZ4	0,37	0,50	2,20	1430	2,47	72,7	71,2	63,7	0,990	3,2	0,4	1,9	14,0	2,25	8,0
IE2	KK 80MA4	0,55	0,75	3,15	1430	3,67	77,1	72,6	67,9	0,990	3,1	0,4	1,9	16,0	2,83	10,0
IE2	KK 90SA4	0,75	1,00	4,10	1420	5,04	79,6	76,2	72,4	0,990	3,5	0,3	1,6	30,0	3,33	14,4
IE2	KK 90LB4	1,1	1,50	6,00	1410	7,45	81,4	79,0	74,2	0,990	3,4	0,2	1,5	40,0	4,10	15,6

Potential Explosive Atmospheres - ATEX

Increased Safety and Non Sparking



7. Overall dimensions (mm)

B3 IM B3 (IM 1001)

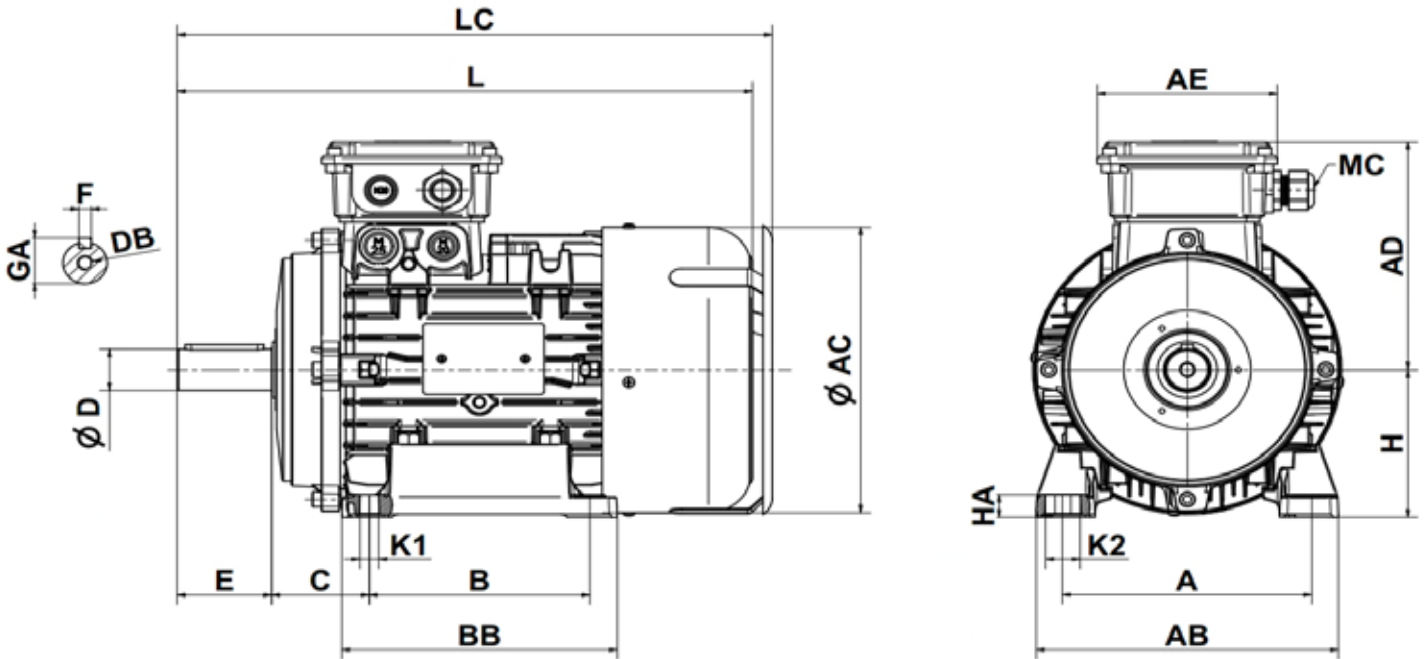

Size	B	A	HA	BB	AB	AC	AD	AE	C	H	L	LR	K1	K2	MC	D	E	GA	F	DB
56	71	90	10	90	108	110	107	100	36	56	189	257	6	11	M16	9	20	10,2	3	M3x9
63	80	100	10	105	120	121	112	100	40	63	219	220	7	12	M16	11	23	12,5	4	M4x10
71	90	112	12,5	108	136	138	122	100	45	71	255	258	7	12	M20	14	30	16	5	M5x15
80	100	125	14,5	125	154	155	140	114	50	80	285	293	10	16,5	M20	19	40	21,5	6	M6x16
90S	100	140	15,2	130	174	176	145	114	56	90	316	317	10	17,5	M20	24	50	27	8	M8x19
90L	125	140	15,2	155	174	176	145	114	56	90	340	341	10	17,5	M20	24	50	27	8	M8x19
100	140	160	15,2	175	192	194	156	114	63	100	379	378	12	22	M20	28	60	31	8	M10x22
112	140	190	15,2	177	224	220	166	114	70	112	392	395	12	22	M32	28	60	31	8	M10x22
132S	140	216	17,5	180	260	258	198	124	89	132	463	477	12	28	M32	38	80	41	10	M12x28
132L	178	216	17,5	216	260	258	198	124	89	132	500	514	12	28	M32	38	80	41	10	M12x28
160S	210	254	21	264	318	310	243	185	108	160	603	618	14,5	30	M32	42	110	45	12	M16x36
160L	254	254	21	308	318	310	243	185	108	160	647	662	14,5	30	M32	42	110	45	12	M16x36

Potential Explosive Atmospheres - ATEX

Increased Safety and Non Sparking

Overall dimensions (mm)

B5 IM B5 (IM 3001)

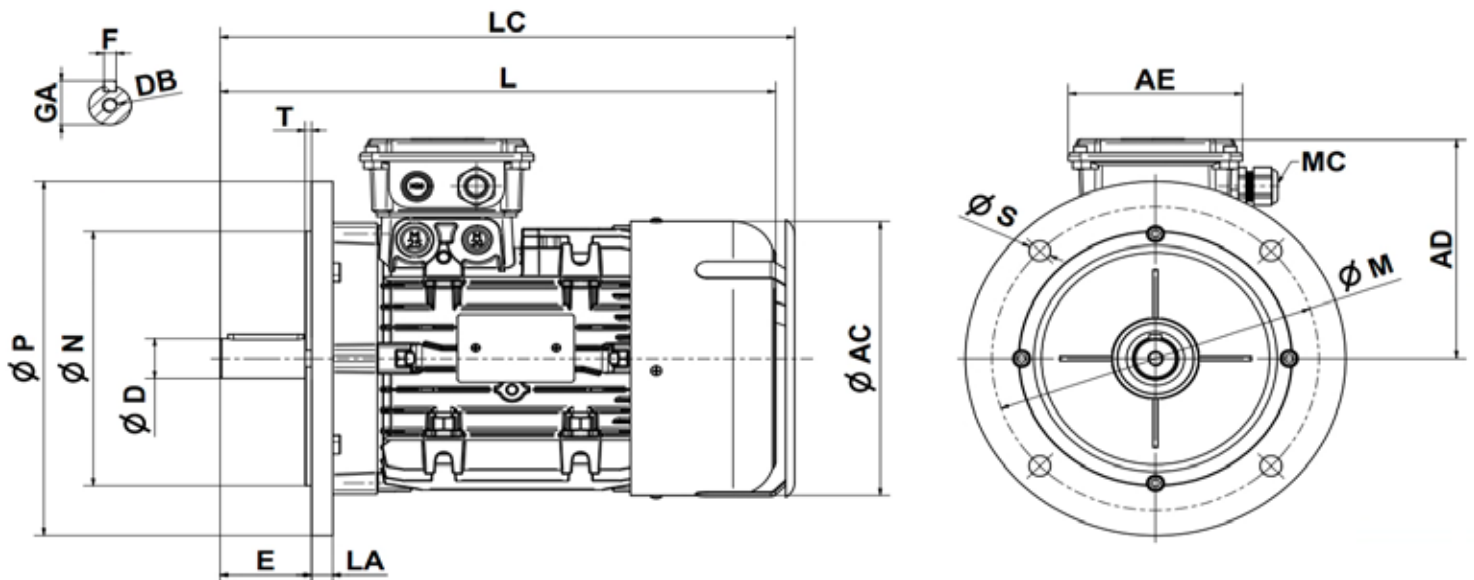

Size	ØP	ØN	LA	ØM	T	S
56	120	80	8	100	3	7
63	140	95	10	115	3	10
71	140	95	9	115	3	10
71	160	110	9,9	130	3,5	10
80	160	110	8,5	130	3,5	10
80	200	130	10,7	165	3,5	12
90	160	110	7,5	165	3,5	10
90	200	130	10,3	165	3,5	12
100	200	130	10	165	3,5	12
100	250	180	14	215	4	14,5
112	250	180	14	215	4	14,5
132	250	180	14	215	4	14,5
132	300	230	19,8	265	4	14,5
160	350	250	15	300	5	18,5

Potential Explosive Atmospheres - ATEX

Increased Safety and Non Sparking



7. Overall dimensions (mm)

B14 IM B14 (IM 3601)

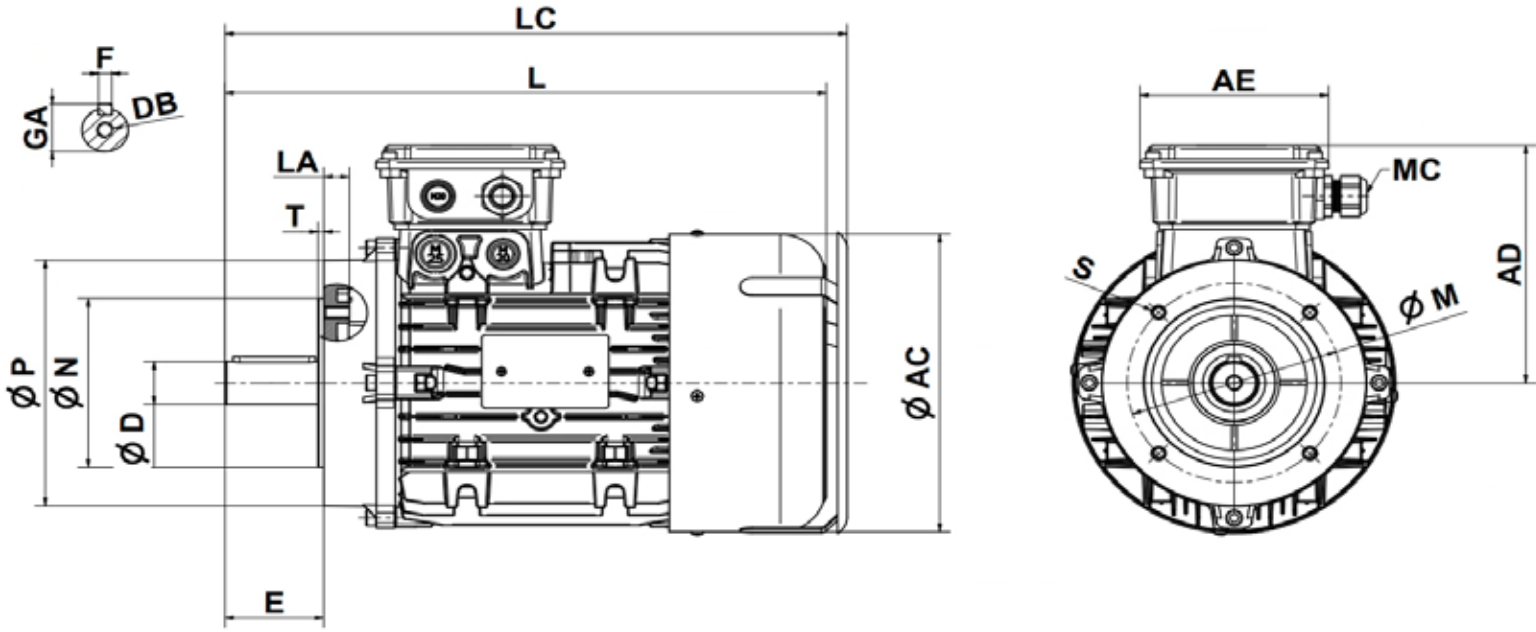

Size	ØP	ØN	LA	ØM	T	S
56	80	50	7,5	65	2,5	M5
63	80	50	8,5	65	2,5	M5
63	90	60	8	75	2,5	M5
63	105	70	8	85	2,5	M6
63	120	80	12	100	3	M6
71	90	60	12	75	2,5	M5
71	105	70	11,5	85	2,5	M6
71	120	80	13	100	3	M6
71	140	95	14	115	3	M8
80	105	70	12,2	85	2,5	M6
80	120	80	12	100	3	M6
80	140	95	19	115	3	M8
80	160	110	20	130	3,5	M8
90	120	80	14	100	3	M6
90	140	95	14,5	115	3	M8
90	160	110	20	130	3,5	M8
100	120	80	15	100	3	M6
100	160	110	15,5	130	3,5	M8
100	200	130	22	165	3,5	M10
112	140	95	15,8	115	3	M8
112	160	110	15,8	130	3,5	M8
132	200	130	21,5	165	3,5	M10
160	250	180	13	215	4	M12

8. Spare Parts

8.1 Personnel qualification

Overhauls and repairs must be carried out only by qualified people in accordance with the standard EN 60079-17 or national standards (last edition). Qualified people must have knowledge about explosion protection. Repairs must be made regarding the rules as define in EN 60079-19 standard. These repairs can only be done under the control or in agreement with ELPROM or by an ATEX certified workshop. In case these rules are not respected, the product won't be covered by Elprom ATEX certification anymore.

8.2 Spare Parts

All motors components must be replaced with original spare parts. In these case contact ELPROM directly and provide the serial number of the motor in order to be authorized for the repair or the motor itself.

1	Drive end shield (B3) – Flange (B5 – B14)	8	Bearings
2	Frame complete with winding	9	Shaft key
3	Non drive end shield	10	Wave spring
4	Terminal box	11	Fan (complete of fixing collar)
5	Terminal box cover	12	Fan cover
6	Feet (removable from 63 to 160)	13	Cable gland
7	Shaft complete of rotor	14	Terminal board

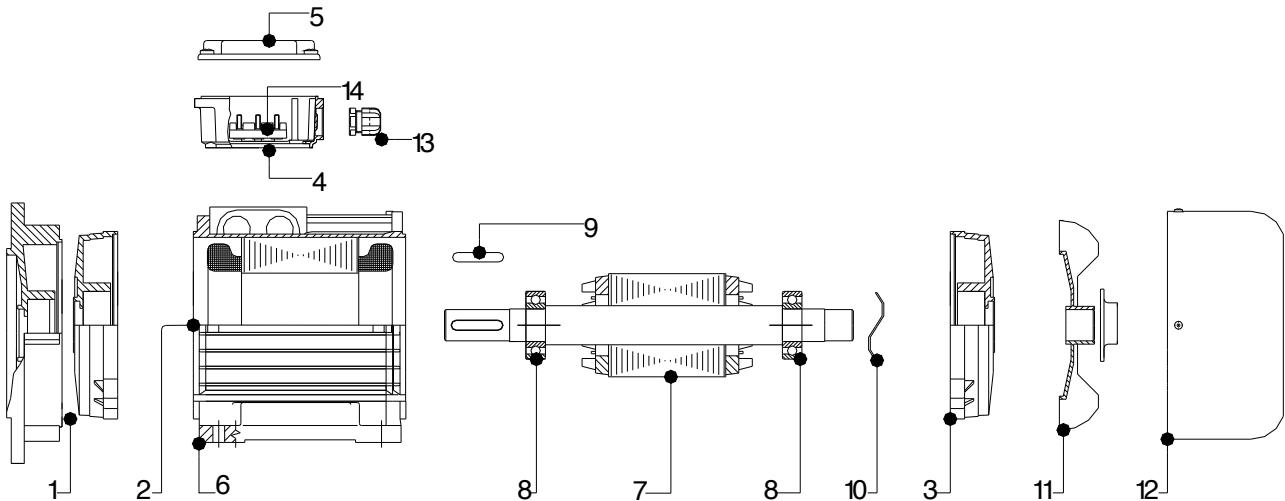



[1]

EU-TYPE EXAMINATION CERTIFICATE[2] **Equipment intended for use in potentially explosive atmospheres Directive 2014/34/EU – Annex III**[3] Certificate Number: **EPT 19 ATEX 3409 X issue 4**[4] Equipment: **Electric motors**
Series: **J2, K2, JH & KH**[5] Manufacturer: **ORANGE1 ELECTRIC MOTORS S.p.A.**[6] Address: **Via Mantova, N. 93 – 43122 Parma - Italy**

[7] This equipment and its accepted variations are specified in the annex to this Certificate.

[8] Eurofins Product Testing Italy S.r.l., Notified Body n. 0477 in accordance with Article 21 of the Directive 2014/34/EU of the European Parliament and of the Council of 26th February 2014, certifies that this equipment has been found to comply with the Essential Health and Safety Requirements relating to the design and construction of equipment intended for use in potentially explosive atmospheres given in Annex II of the Directive. The examination and test results are recorded in the confidential Report N°EPT.23.REL.02/2213098.

[9] Compliance with the essential health and safety requirements is assured through the verification of them and by compliance with the following harmonized standards:

EN IEC 60079-0:2018, EN 60079-1:2014, EN 60079-7:2015+A1:2018, EN 60079-31:2014

[10] If the sign "X" is placed after the Certificate number, it indicates that the equipment is subject to the special conditions for safe use specified in the annex to this Certificate.

[11] This EU-TYPE EXAMINATION CERTIFICATE relates only to the design, the exam and the tests of the specified equipment.
Further requirements of the Directive 2014/34/EU apply to the manufacture and supply of this equipment. These requirements are not object of this Certificate.[12] The equipment shall include the sign  and at least one of the following strings:

II 2G Ex eb IIC T4 Gb	-40°C ≤ T_{amb} ≤ +40°C	3Ph, Size 56 and 63 without flat box only for J2 – K2 series.
II 2G Ex eb IIC T3 Gb	-40°C ≤ T_{amb} ≤ +45°C	3Ph, Size 56 and 63 with flat box; all other sizes with and without flat box
II 2G Ex db eb IIC T3 Gb	-40°C ≤ T_{amb} ≤ +45°C	Single phase motors with or without flat box
II 2D Ex tb IIIC T125°C Db		Applicable to all motors; if present it's always in addition to one of the above listed strings

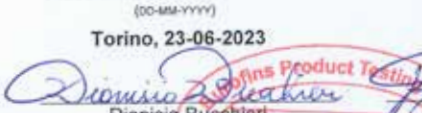
Place and date of issue:
(DD-MM-YYYY)**Torino, 23-06-2023**
Dionisio Bucchieri
Directive Responsible
Paolo Trisoglio
Managing DirectorPRD N° 1198
Signatory of EA, IAF and ILAC Mutual Recognition Agreements
CP-ATEX-MOD-25-00

This Certificate has 10 pages and it is reproducible only in its entirety. Conditions of validity are reported below.



[1]

TYPE EXAMINATION CERTIFICATE

- [2] Equipment intended for use in potentially explosive atmospheres Directive 2014/34/EU
- [3] Certificate Number: **EPTI 20 ATEX 0378 X** **issue 1**
- [4] Equipment: **Asynchronous motor**
Model: **J3, JK, K3 & KK**
- [5] Manufacturer: **ORANGE1 ELECTRIC MOTORS S.p.A.**
- [6] Address: **Via Mantova, N. 93 – 43122 Parma - Italy**
- [7] This equipment and its accepted variations are specified in the annex to this Certificate.
- [8] Eurofins Product Testing Italy S.r.l. certifies that this equipment has been found to comply with the Essential Health and Safety Requirements relating to the design and construction of equipment intended for use in potentially explosive atmospheres given in Annex II of the Directive.
The examination and test results are recorded in the confidential Report N° EPT.23.REL.01/2113113.
- [9] Compliance with the essential health and safety is assured through the verification of them and by compliance with the standard:
EN IEC 60079-0:2018, EN 60079-1:2014, EN 60079-7:2015+A1:2018, EN 60079-31:2014
- [10] If the sign "X" is placed after the Certificate number the equipment is subjected to special conditions for safe use specified in the annex to this Certificate.
- [11] This TYPE EXAMINATION CERTIFICATE relates only to the design, the exam and the tests of the equipment specified.
Further requirements of the Directive 2014/34/EU apply to the manufacture and supply of this equipment. These requirements are not object of this Certificate.
- [12] The equipment shall include the sign  and the following string:
- | | |
|--------------------------------------|--------------------------|
| II 3D Ex tc IIIB T125°C Dc | Applicable to all motors |
| II 3G Ex ec IIC T4...T3 Gc | For three-phase motors |
| II 3G Ex db ec IIC T4...T3 Gc | For single-phase motors |

Place and date of issue:
(DD-MM-YYYY)

Torino, 30-03-2023

Dionisio Buccieri
Directive Responsible



ORANGE1
HOLDING

ORANGE1
Electric Motors Spa

Administrative Headquarter

Piazza della Repubblica 28
20124 - Milano Italy

Production plants

Via Angelo Messedaglia 4
32030 - Arsìè (BL) Italy
T. +39 0439 750067
F. +39 0439 750070

Via A. Grandi 23
47030 - San Mauro Pascoli (FC) Italy
T. +39 0541 815611
F. +39 0541 815684

Via Mantova nr. 93
43122 Parma (PR) Italy
T. +39 0521 272383
F. +39 0521 272686

info@orange1.eu
www.orange1.eu

follow us   

