Brochure Técnica

Motores Eléctricos Techttop

Transformamos la energía en movimiento

Los motores TechTop están diseñados y fabricados para ofrecer un alto rendimiento con un impacto ambiental mínimo.

Hacer que nuestros productos estén disponibles cuándo y dónde más se necesitan es tan importante como ofrecer un servicio eficiente y rápido.

DIMOTOR
TECHTOP GROUP

 **TECHTOP**®



ÍNDICE

Motores asíncronos trifásicos CARCASA DE ALUMINIO

Serie T1A - IE1
Serie T3A - IE3
Serie T4A - IE4



01.

Motores asíncronos trifásicos CARCASA DE FUNDICIÓN

Serie T3C - IE3
Serie T4C - IE4



09.

Motores asíncronos trifásicos ATEX

Zona 2-22



15.

Motores asíncronos monofásicos PAR NORMAL

Serie MY / MY2



17.

Motores asíncronos monofásicos PAR FUERTE

Serie ML / ML2



21.

Motores conmutados electrónicamente Serie EC / ECI

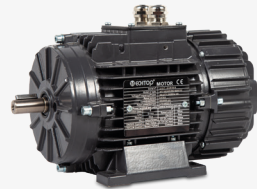

25.

Características generales

Conexiones, rodamientos, certificados
y detalle de placa de características

TECHTOP		MOTOR		IEC 60034		IEC 60034		IEC 60034				
TYPE	T 160M-4 T3CR 160M-4	(H)	SI-100%	2020	IEC60034	SN DZ	1912510356	IEC1 F	IP55	IM B3	NAN: 127 HGS	
V.D./Y	Hz	min	A	cos φ	IEF-91.4 (100%)	400/690	50	1450	11	20.68/11.89	0.84	91.7 (50%)
415/718	50	1450	11	19.91/11.89	0.84							
440/760	60	1740	11	18.8/10.9	0.84	BEARING DE-NDE:						
460/795	60	1740	11	18.0/10.4	0.84	6309-6309						

DIMOTOR S.A. C/Corral's Nous, 61 Sabadell (Spain)

29.

Configurador Techtop
Soporte documental



32.

SERIE TA

MOTORES ASÍNCRONOS TRIFÁSICOS CARCASA DE ALUMINIO 'ECOL'

CARACTERÍSTICAS

- Ahorro de energía, alta eficiencia
- Alto par de arranque
- Diseño versátil y fácil de adaptar a una gran variedad de aplicaciones
- Patas desmontables
- Posición caja de bornes arriba, izquierda o derecha
- Eficiencia IE1, IE2, IE3, IE4
- Diseño compacto

APLICACIONES

- > Bombas
- > Plantas de tratamiento de aguas
- > Compresores
- > Ventiladores
- > Reductores
- > Transmisión de potencia
- > Papeleras
- > Cintas transportadoras
- > Sector agrícola
- > Minería
- > Equipos hidráulicos



IE1 RAL 9006
IE3 e IE4 RAL 7024

DIAGRAMA DE DESPIECE DEL MOTOR CARCASA DE ALUMINIO

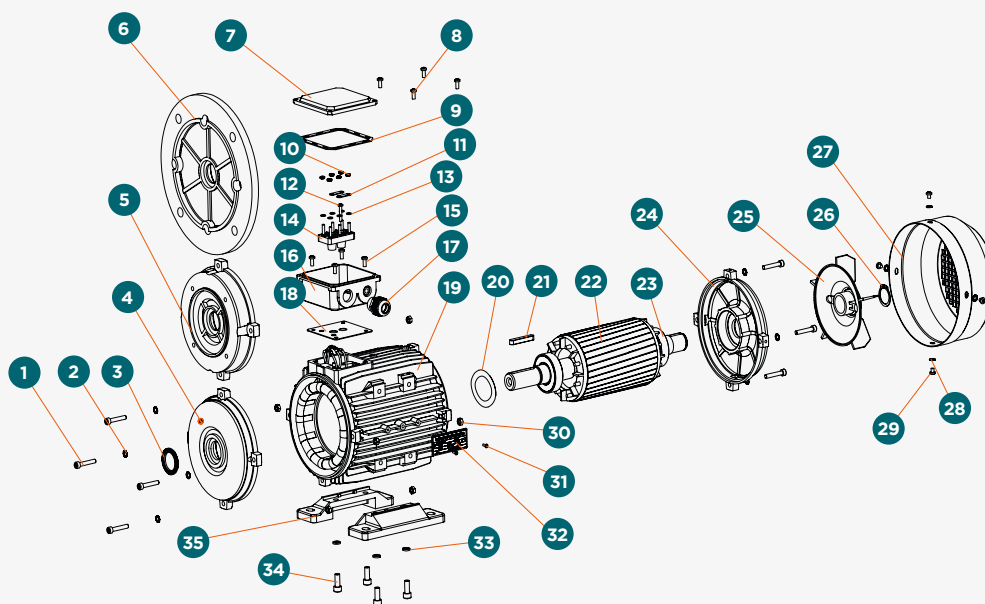

- | | | | |
|---------------------------------|--------------------------------------|-------------------------------|--|
| 1 Tornillo soporte LA | 10 Tuercas de fijación de terminales | 19 Carcasa | 28 Arandela caperuza protectora |
| 2 Arandela | 11 Pletinas de conexión | 20 Arandela ondulada | 29 Tornillo caperuza protectora |
| 3 Retén | 12 Bornes | 21 Chaveta | 30 Tuercas de fijación soporte lado ventilador |
| 4 Soporte lado accionamiento | 13 Arandela interior caja de bornes | 22 Rotor | 31 Tornillos placa de datos |
| 5 Brida B14 | 14 Bornera | 23 Rodamiento lado ventilador | 32 Placa de características |
| 6 Brida B5 | 15 Tornillo interior caja de bornes | 24 Soporte lado ventilador | 33 Tuercas de fijación patas |
| 7 Tapa caja de bornes | 16 Caja de bornes | 25 Ventilador | 34 Tornillos de fijación patas |
| 8 Tornillos caja de bornes | 17 Prensaestopas | 26 Seeger/circlip | 35 Patas |
| 9 Junta superior caja de bornes | 18 Junta inferior caja de bornes | 27 Caperuza protectora | |

MEDIDAS EXTERIORES Y FORMAS CONSTRUCTIVAS

Tipo	B3				Eje								General							
	H	A	B	C	D	E	F	G	K	SS	XX	ZZ	AA	AD	HD	AC	L	TBS	TBW	TBH
TA 56	56	90	71	36	Ø9	20	3	7.2	6×9	M4	10	14	112	151	95	Ø110	195	16.5	83	83
TA 63	63	100	80	40	Ø11	23	4	8.5	7×10	M4	10	14	124	172	109	Ø122	217	10	98	98
TA 71	71	112	90	45	Ø14	30	5	11	7×10	M5	12	17	140	189	118	Ø138	245	16	98	98
TA 80	80	125	100	50	Ø19	40	6	15.5	10×15	M6	16	21	160	214	134	Ø157	277/304*	26.5	109	109
TA 90S	90	140	100	56	Ø24	50	8	20	10×15	M8	19	25	176	235	145	Ø177	315/340*	28.5	109	109
TA 90L	90	140	125	56	Ø24	50	8	20	10×15	M8	19	25	176	235	145	Ø177	340/365*	28.5	109	109
TA 100	100	160	140	63	Ø28	60	8	24	12×16	M10	22	30	200	260	160	Ø199	376/411*	32	118	118
TA 112	112	190	140	70	Ø28	60	8	24	12×16	M10	22	30	224	283	171	Ø220	398	33	118	118
TA 132S/M	132	216	140/178	89	Ø38	80	10	33	12×16	M12	28	37	260	323	191	Ø261	460/498	36.5	118	118
TA 160M/L	160	254	210/254	108	Ø42	110	12	37	15×21	M16	36	45	314	391	231	Ø314	616/660	64	148	148

Tipo	KK	B5						B14						B5R						B14B						
		N	M	P	S	T	R	N	M	P	S	T	R	N	M	P	S	T	R	N	M	P	S	T	R	
TA 56	1-M16 x 1.5	Ø80	Ø100	Ø120	Ø7	3	0	Ø50	Ø65	Ø80	M5	2.5	0													
TA 63	1-M16 x 1.5	Ø95	Ø115	Ø140	Ø10	3	0	Ø60	Ø75	Ø90	M5	2.5	0													
TA 71	1-M20 x 1.5	Ø110	Ø130	Ø160	Ø10	3.5	0	Ø70	Ø85	Ø105	M6	2.5	0	Ø95	Ø115	Ø140	3	Ø10	0	Ø95	Ø115	Ø140	3	M8	0	
TA 80	1-M20 x 1.5	Ø130	Ø165	Ø200	Ø12	3.5	0	Ø80	Ø100	Ø120	M6	3	0	Ø110	Ø130	Ø160	3.5	Ø10	0	Ø110	Ø130	Ø160	3.5	M8	0	
TA 90S/L	1-M20 x 1.5	Ø130	Ø165	Ø200	Ø12	3.5	0	Ø95	Ø115	Ø140	M8	3	0	Ø110	Ø130	Ø160	3.5	Ø10	0	Ø110	Ø130	Ø160	3.5	M8	0	
TA 100	2-M20 x 1.5	Ø180	Ø215	Ø250	Ø15	4	0	Ø110	Ø130	Ø160	M8	3.5	0	Ø130	Ø165	Ø200	3.5	Ø12	0	Ø130	Ø165	Ø200	3.5	M10	0	
TA 112	2-M25 x 1.5	Ø180	Ø215	Ø250	Ø15	4	0	Ø110	Ø130	Ø160	M8	3.5	0	Ø130	Ø165	Ø200	3.5	Ø12	0	Ø130	Ø165	Ø200	3.5	M10	0	
TA 132S/M	2-M25 x 1.5	Ø230	Ø265	Ø300	Ø15	4	0	Ø130	Ø165	Ø200	M10	3.5	0	Ø180	Ø215	Ø250	4	Ø15	0	Ø180	Ø215	Ø250	4	M12	0	
TA 160M/L	2-M32 x 1.5	Ø250	Ø300	Ø350	Ø19	5	0	Ø180	Ø215	Ø250	M12	4	0													

* Motores de carcasa reducida

IM B3 56-160

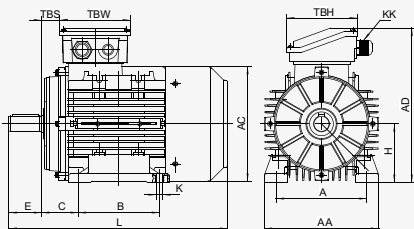

IM B5 56-160

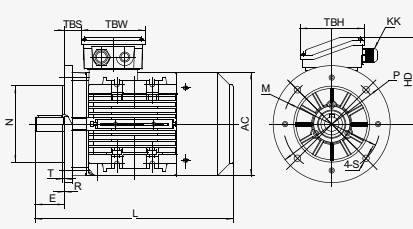

IM B14 56-160

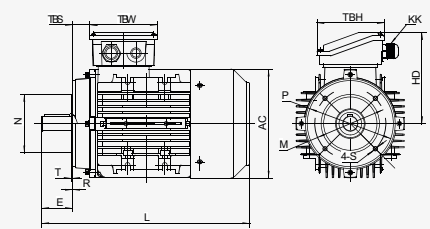

IM B34 56-160

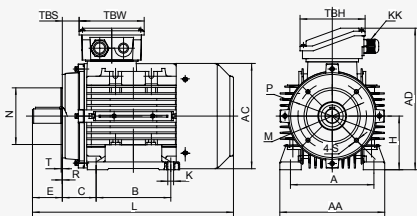

IM B35 56-160

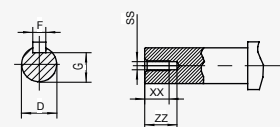
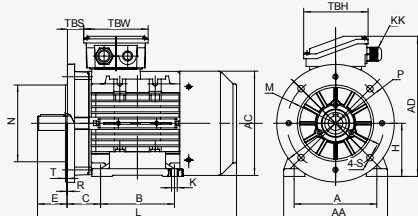

IM B3 180-200

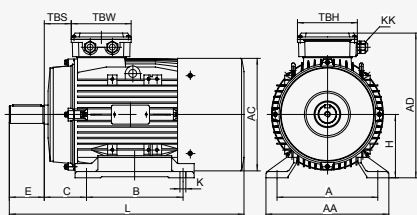

IM B5 180-200

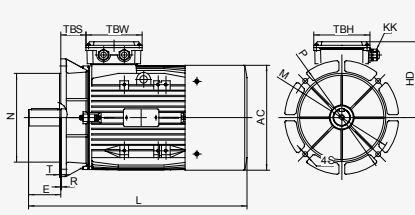

IM B35 180-200

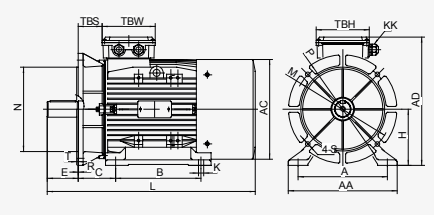

SERIE T1A

MOTORES ASÍNCRONOS TRIFÁSICOS - 1 VELOCIDAD - CARCASA DE ALUMINIO - CLASE DE EFICIENCIA IE1

Carcasa 56-160; Polos 2-4-6-8.

2 POLOS - 3000 RPM - 50HZ - 3600 RPM - 60 HZ

Tipo	Potencia	Corriente (A)			Corriente (A)			Corriente (A)			Velocidad (r/min)	Eficiencia			Factor de potencia	Tst/Tn	Tmax/Tn	Tmin/Tn	Ist/In	dB(A)	Peso (kg)	Inercia (kg·m ²)
		220V	380V	660V	230V	400V	690V	240V	415V	720V		100%	75%	50%								
T1A 56I-2	0.09	0.64	0.37	0.21	0.60	0.35	0.20	0.58	0.34	0.19	2800	55.6	49.6	39.2	0.67	2.4	2.6	2.2	3.5	58	2.80	0.00010173
T1A 56Z-2	0.12	0.68	0.39	0.23	0.64	0.37	0.21	0.62	0.36	0.21	2840	65.6	61.8	53.2	0.71	2.3	2.6	2.1	4.3	58	3.00	0.00012837
*T1A 56Z-2	0.18	0.93	0.53	0.31	0.88	0.51	0.29	0.85	0.49	0.28	2780	66.5	64.2	56.8	0.77	2.3	2.5	2.4	4.1	61	3.50	0.00014170
T1A 63I-2	0.18	0.95	0.55	0.32	0.90	0.52	0.30	0.87	0.50	0.29	2840	66.5	64.3	56.5	0.75	2	2.5	1.7	4.7	61	3.70	0.00014970
T1A 63Z-2	0.25	1.21	0.70	0.40	1.15	0.66	0.38	1.11	0.64	0.37	2840	69.8	66.2	56.8	0.78	2.5	2.7	2	5.2	61	4.10	0.00017102
*T1A 63Z-2	0.37	1.79	1.03	0.60	1.70	0.98	0.57	1.64	0.95	0.55	2840	69.8	65.6	61.2	0.78	2	2.4	1.8	5.1	62	4.60	0.00020300
T1A 71I-2	0.37	1.66	0.96	0.55	1.58	0.91	0.53	1.52	0.88	0.51	2840	71.5	70.9	65.8	0.82	2	2.2	1.4	5.1	64	5.34	0.00031368
T1A 71Z-2	0.55	2.41	1.39	0.80	2.29	1.32	0.76	2.21	1.27	0.74	2850	73.2	73.4	69.1	0.82	1.8	2.3	1.4	5.1	64	6.14	0.00038379
*T1A 71Z-2	0.75	3.05	1.76	1.02	2.90	1.67	0.97	2.79	1.61	0.93	2840	77.1	77.5	74.8	0.84	2.6	2.6	1.7	6	65	7.10	0.00047547
T1A 80I-2	0.75	3.35	1.93	1.12	3.18	1.84	1.06	3.07	1.77	1.02	2870	73.7	71.7	65.4	0.8	2.1	2.5	1.5	5.7	67	8.15	0.00089634
T1A 80Z-2	1.1	4.41	2.55	1.47	4.19	2.42	1.40	4.04	2.33	1.35	2870	79	78.8	75.4	0.83	2.6	2.8	1.8	6.5	67	9.70	0.00112377
*T1A 80Z-2	1.5	5.87	3.39	1.96	5.58	3.22	1.86	5.38	3.10	1.79	2870	81	81.1	78.5	0.83	2.7	3	2.1	6.8	70	11.00	0.00135120
T1A 90S-2	1.5	5.94	3.43	1.98	5.65	3.26	1.88	5.44	3.14	1.81	2880	80	79.8	76.7	0.83	2.3	2.8	1.4	6.6	72	12.30	0.00185573
T1A 90L1-2	2.2	8.25	4.77	2.75	7.84	4.53	2.61	7.56	4.36	2.52	2880	83.5	84	82.2	0.84	2.6	2.7	1.8	7.1	72	14.90	0.00230595
*T1A 90L2-2	3	10.8	6.24	3.60	10.3	5.92	3.42	9.89	5.71	3.30	2900	86	86.5	85.2	0.85	2.9	3	1.9	8.1	74	17.10	0.00296596
T1A 100L1-2	3	11.3	6.54	3.77	10.8	6.21	3.59	10.4	5.99	3.46	2900	83	82.7	80	0.84	2.7	3.2	2.1	7.7	76	20.10	0.00377615
*T1A 100L2-2	4	15.0	8.67	5.00	14.3	8.23	4.75	13.7	7.93	4.58	2890	84.5	84.4	82.1	0.83	3.1	3.6	2.8	8.1	77	23.00	0.00466405
T1A 100L3-2	5.5	18.7	10.8	6.23	17.8	10.25	5.92	17.1	9.88	5.70	2900	88	88.6	87.7	0.88	3.3	3.6	2.5	10.1	78	26.00	0.00590710
T1A 112M1-2	4	14.2	8.2	4.75	13.5	7.81	4.51	13.0	7.53	4.34	2910	85	85	83.6	0.87	2.8	3.6	1.7	9.2	77	26.15	0.00631057
*T1A 112M2-2	5.5	19.0	11.0	6.34	18.1	10.4	6.02	17.4	10.1	5.80	2900	86.5	87	86	0.88	3	3.8	2.2	9.8	78	31.20	0.00779613
*T1A 112M3-2	7.5	25.8	14.9	8.59	24.5	14.1	8.16	23.6	13.6	7.87	2910	88	88	86.4	0.87	3.8	4.2	2.7	10.3	80	37.00	0.00983332
T1A 132S1-2	5.5	18.8	10.9	6.27	17.9	10.3	5.95	17.2	9.9	5.74	2900	86.5	87.2	86.1	0.89	2.1	2.9	1.7	7.8	80	37.60	0.01205798
T1A 132S2-2	7.5	25.7	14.8	8.55	24.4	14.1	8.13	23.5	13.6	7.83	2890	88.4	89.1	88.4	0.87	2.7	3.2	2.5	8.2	80	45.00	0.01521165
*T1A 132M1-2	9.2	30.6	17.6	10.2	29.0	16.8	9.68	28.0	16.2	9.33	2910	88	88.1	86.5	0.9	3.1	3.8	1.7	9.7	81	51.00	0.01783446
*T1A 132M2-2	11	36.5	21.1	12.2	34.7	20.0	11.6	33.5	19.3	11.2	2920	89	89	87.3	0.89	3.3	4	1.8	10.7	83	56.50	0.02035740
*T1A 132M3-2	15	50.4	29.1	16.8	47.9	27.7	16.0	46.2	26.7	15.4	2940	91	90.7	89.1	0.86	4	4.5	2.5	14	86	73.00	0.02855696
T1A 160M1-2	11	38.3	22.1	12.8	36.4	21.0	12.1	35.1	20.2	11.7	2940	90	90	88.6	0.84	2.6	3.1	1.5	7.9	86	72.00	0.04437972
T1A 160M2-2	15	49.3	28.5	16.4	46.9	27.1	15.6	45.2	26.1	15.1	2940	89.9	90.4	89.6	0.89	2.6	2.9	1.4	8.5	86	82.00	0.05580496
T1A 160L1-2	18.5	62.9	36.3	21.0	59.8	34.5	19.9	57.6	33.3	19.2	2950	91	91.2	89.7	0.85	2.8	3.5	1.7	9.4	86	94.10	0.06559287
T1A 160L2-2	22	72.3	41.8	24.1	68.7	39.7	22.9	66.2	38.2	22.1	2950	92	92	90.9	0.87	3.4	3.2	1.9	9.4	91	104.50	0.07701810

4 POLOS - 1500 RPM - 50 HZ - 1800 RPM - 60 HZ

Tipo	Potencia	Corriente (A)			Corriente (A)			Corriente (A)			Velocidad (r/min)	Eficiencia			Factor de potencia	Tst/Tn	Tmax/Tn	Tmin/Tn	Ist/In	dB(A)	Peso (kg)	Inercia (kg·m ²)
		220V	380V	660V	230V	400V	690V	240V	415V	720V		100%	75%	50%								
T1A 56I-4	0.06	0.54	0.31	0.18	0.52	0.30	0.17	0.50	0.29	0.17	1400	52.8	47.7	38.7	0.55	3.1	3.2	3	3.2	50	2.90	0.00018990
T1A 56Z-4	0.09	0.71	0.41	0.24	0.68	0.39	0.23	0.65	0.38	0.22	1400	56.2	51.7	43.1	0.59	2.3	2.5	2.8	3.1	50	3.20	0.00023991
*T1A 56Z-4	0.12	0.89	0.51	0.30	0.84	0.49	0.28	0.81	0.47	0.27	1390	58.5	54.3	45.6	0.61	2.65	2.8	2.7	3.2	52	3.70	0.00026491
T1A 63I-4	0.12	0.81	0.47	0.27	0.77	0.44	0.26	0.74	0.43	0.25	1395	60.1	56.7	48.4	0.65	2.1	2.3	1.7	3.5	52	3.70	0.00027304
T1A 63Z-4	0.18	1.06	0.61	0.35	1.01	0.58	0.34	0.97	0.56	0.32	1370	64.7	60.4	55.8	0.69	2.2	2.3	2.1	3.5	52	4.40	0.00033806
*T1A 63Z-4	0.25	1.30	0.75	0.43	1.23	0.71	0.41	1.19	0.69	0.40	1360	68.5	68.8	65.1	0.74	2.1	2.3	2	3.9	54	5.00	0.00040807
T1A 71I-4	0.25	1.40	0.81	0.47	1.33	0.77	0.44	1.28	0.74	0.43	1390	69	67.9	62.4	0.68	2.2	2.3	1.8	4.1	55	5.06	0.00050666
T1A 71Z-4	0.37	1.85	1.07	0.62	1.76	1.02	0.59	1.70	0.98	0.57	1385	70	70.5	66.2	0.75	2	2.2	1.7	4.3	55	5.96	0.00071439
*T1A 71Z-4	0.55	2.92	1.69	0.97	2.78	1.60	0.93	2.68	1.55	0.89	1380	66	66.5	63	0.75	2.2	2.3	1.8	4.7	57	7.06	0.00091936
T1A 80I-4	0.55	2.64	1.53	0.88	2.51	1.45	0.84	2.42	1.40	0.81	1420	73	72.2	67.1	0.75	2	2.3	1.6	4.8	57	8.25	0.00145276
T1A 80Z-4	0.75	3.39	1.96	1.13	3.22	1.86	1.08	3.11	1.79	1.04	1410	76.5	77.8	75.4	0.76	2.1	2.3	1.7	4.8	58	9.75	0.00169042
*T1A 80Z-4	1.1	4.91	2.84	1.64	4.67	2.70	1.56	4.50	2.60	1.50	1390	77.5	79	77.4	0.76	2.3	2.4	2	5	61	11.20	0.00216574
T1A 90S-4	1.1	4.76	2.75	1.59	4.52	2.61	1.51	4.36	2.52	1.45	1410	79	79.4	76.5	0.77	2.5	2.7	2.2	5.5	61	12.30	0.00267500
T1A 90L1-4	1.5	6.26	3.62	2.09	5.95	3.44	1.98	5.74	3.31	1.91	1410	80.8	81.7	79.7	0.78	2.9	3	2.5	6.2	61	15.10	0.00351865
T1A 90L1-4B	1.85	7.57	4.37	2.52	7.19	4.15	2.40	6.93	4.00	2.31	1415	81.4	82.3	80.6	0.79	3.1	3	2.5	6.5	62	16.60	0.00418540
*T1A 90L2-4	2.2	8.84	5.10	2.95	8.39	4.85	2.80	8.09	4.67	2.70	1410	81.9	83.2	82	0.8	3.2	3.1	2.6	6.7	64	17.78	0.00468546
T1A 100L1-4	2.2	8.88	5.13	2.96	8.44	4.87	2.81	8.13	4.70	2.71	1430	82.5	83.5	82.1	0.79	2.2	2.7	1.9	6.3	64	19.75	0.00677509
T1A 100L2-4	3	11.4	6.58	3.80	10.8	6.25	3.61	10.4	6.02	3.48	1430	84.5	85.4	84.4	0.82	2.5	2.8	2.1	6.7	64	23.10	0.00842419
*T1A 100L3-4	4	16.6	9.61	5.55	15.8	9.13	5.27	15.2	8.80	5.08	1440	84.3	84.3	81.9	0.75	3	3.5	2.6	7.1	65	28.20	0.01073293
T1A 112M1-4	4	15.8	9.11	5.26	15.0	8.66	5.00	14.5	8.34	4.82	1440	85.5	85.6	83.7	0.78	2.3	3.3	2.1	7.8	65	29.80	0.01322838
*T1A 112M2-4	5.5	20.4	11.8	6.81	19.4	11.2	6.47	18.7	10.8	6.23	1440	87.5	88.4	87.8	0.81	2.6	3.5	2.4	7.9	71	36.00	0.01683909
T1A 132S-4	5.5	20.5	11.9	6.84	19.5	11.3	6.50	18.8	10.9	6.26	1450	86	86.4	84.8	0.82	1.8	2.9	1.7	7.1	71	42.20	0.02801223
T1A 132M1-4	7.5	26.6	15.4	8.87	25.3	14.6	8.43	24.4														

6 POLOS - 1000 RPM - 50 HZ - 1200 RPM - 60 HZ

Tipo	Potencia	Corriente (A)			Corriente (A)			Corriente (A)			Velocidad (r/min)	Eficiencia			Factor de potencia	Tst/Tn	Tmax/Tn	Tmin/Tn	lst/ln	dB(A)	Peso (kg)	Inercia (kg·m ²)
		220V	380V	660V	230V	400V	690V	240V	415V	720V		100%	75%	50%								
TIA 631-6	0.09	0.74	0.42	0.25	0.70	0.40	0.23	0.67	0.39	0.22	870	51.1	49.2	42.5	0.63	1.8	2	1.9	2.6	50	4.20	0.00041778
TIA 632-6	0.12	0.91	0.53	0.30	0.87	0.50	0.29	0.84	0.48	0.28	850	51.6	51.2	43.1	0.67	1.8	2	1.8	2.7	50	4.50	0.00051688
*TIA 633-6	0.18	1.33	0.77	0.44	1.26	0.73	0.42	1.22	0.70	0.41	850	54	52	47.6	0.66	2	2.1	1.9	3	52	4.80	0.00059864
TIA 711-6	0.18	1.25	0.72	0.42	1.19	0.69	0.40	1.14	0.66	0.38	890	56.6	54.4	46.3	0.67	1.9	2.2	1.8	3.1	52	5.60	0.00084095
TIA 712-6	0.25	1.62	0.93	0.54	1.54	0.89	0.51	1.48	0.86	0.49	910	61.6	59.7	52.2	0.66	2.1	2.3	1.9	3.4	52	6.00	0.00096467
*TIA 713-6	0.37	2.23	1.28	0.74	2.11	1.22	0.70	2.04	1.18	0.68	900	66.3	65.5	59.7	0.66	2.4	2.5	2.3	3.7	54	6.80	0.00115024
TIA 801-6	0.37	2.42	1.40	0.81	2.30	1.33	0.77	2.21	1.28	0.74	910	61	58.6	50.7	0.66	1.9	2.2	1.8	3.2	56	8.00	0.00159634
TIA 802-6	0.55	2.99	1.73	1.00	2.84	1.64	0.95	2.74	1.58	0.91	920	71.2	71.1	66	0.68	1.9	2.3	1.8	3.8	56	9.25	0.00204109
*TIA 803-6	0.75	3.86	2.23	1.29	3.67	2.12	1.22	3.54	2.04	1.18	910	72	73.1	69.6	0.71	1.9	2.2	1.8	3.9	58	10.60	0.00263409
TIA 90S-6	0.75	4.06	2.34	1.35	3.86	2.23	1.29	3.72	2.15	1.24	940	71.5	70.9	65.8	0.68	1.8	2.2	1.5	4.1	59	11.80	0.00326564
TIA 90L1-6	1.1	5.97	3.45	1.99	5.67	3.27	1.89	5.46	3.15	1.82	930	73.5	73.4	69	0.66	1.9	2.3	1.8	4.1	59	14.20	0.00428110
*TIA 90L2-6	1.5	6.98	4.03	2.33	6.63	3.83	2.21	6.39	3.69	2.13	925	77.5	78.7	76.6	0.73	2.2	2.5	1.9	4.8	61	15.50	0.00548739
TIA 100L1-6	1.5	7.22	4.17	2.41	6.86	3.96	2.29	6.61	3.82	2.20	940	77	77.9	75.3	0.71	1.7	2.2	1.6	4.5	61	18.70	0.00754254
*TIA 100L2-6	2.2	9.71	5.61	3.24	9.22	5.33	3.07	8.89	5.13	2.96	940	79.5	81	79.8	0.75	1.9	2.3	1.7	5	64	22.80	0.00993467
TIA 112M1-6	2.2	10.6	6.11	3.53	10.1	5.80	3.35	9.69	5.59	3.23	945	79.3	79.5	76.5	0.69	1.9	2.3	1.8	4.8	64	24.50	0.01395044
*TIA 112M2-6	3	12.5	7.21	4.17	11.9	6.85	3.96	11.4	6.61	3.81	940	81	84	84.6	0.78	1.6	2.1	1.5	4.8	64	28.50	0.01767543
TIA 132S-6	3	12.5	7.20	4.16	11.8	6.84	3.95	11.4	6.59	3.81	965	84.4	85.7	85.1	0.75	1.7	2.2	1.3	5.6	64	36.40	0.03045714
TIA 132M1-6	4	17.1	9.85	5.69	16.2	9.36	5.40	15.6	9.02	5.21	965	84.5	85.1	83.6	0.73	2	2.6	1.5	5.9	68	42.20	0.03725132
TIA 132M2-6	5.5	23.4	13.5	7.79	22.2	12.8	7.40	21.4	12.4	7.13	965	86	87.6	87.7	0.72	2.1	2.4	1.6	5.8	68	51.40	0.04896639
*TIA 132M3-6	7.5	30.2	17.5	10.1	28.7	16.6	9.58	27.7	16.0	9.23	965	87	87.3	85.8	0.75	2.7	2.9	2	7.3	68	62.60	0.06235504
TIA 160M-6	7.5	30.2	17.5	10.1	28.7	16.6	9.58	27.7	16.0	9.23	965	87	87.8	87.1	0.75	2.4	2.9	1.7	6.7	68	71.40	0.08622631
TIA 160L1-6	11	44.5	25.7	14.8	42.2	24.4	14.1	40.7	23.5	13.6	965	86.8	88.1	87.9	0.75	2.4	2.1	1.2	6.2	73	89.40	0.11687380
TIA 160L2-6	15	56.9	32.8	19.0	54.0	31.2	18.0	52.1	30.1	17.4	970	89	88.2	87.9	0.78	2.6	2.6	1.1	7.7	79	105.00	0.15484950

8 POLOS - 750 RPM - 50 HZ - 900 RPM - 60 HZ

Tipo	Potencia	Corriente (A)			Corriente (A)			Corriente (A)			Velocidad (r/min)	Eficiencia			Factor de potencia	Tst/Tn	Tmax/Tn	Tmin/Tn	lst/ln	dB(A)	Peso (kg)	Inercia (kg·m ²)
		220V	380V	660V	230V	400V	690V	240V	415V	720V		100%	75%	50%								
TIA 711-8	0.09	1.05	0.61	0.35	1.00	0.58	0.33	0.96	0.56	0.32	680	38.2	28.8	24.1	0.59	1.8	2.2	1.7	2.3	50	5.60	0.00071723
TIA 712-8	0.12	1.20	0.70	0.40	1.14	0.66	0.38	1.10	0.64	0.37	690	42.3	36.6	27.7	0.62	1.8	2.2	1.7	2.5	50	6.00	0.00084095
TIA 801-8	0.18	1.48	0.86	0.49	1.41	0.81	0.47	1.36	0.79	0.45	690	55	51.5	43.4	0.58	2.2	2.4	2	3	52	8.30	0.00202145
TIA 802-8	0.25	1.94	1.12	0.65	1.84	1.06	0.61	1.78	1.03	0.59	690	58.5	55.5	47.9	0.58	2.3	2.4	2	3.1	52	9.30	0.00232255
*TIA 803-8	0.37	2.46	1.42	0.82	2.34	1.35	0.78	2.26	1.30	0.75	700	67	62.5	58.3	0.59	2	2.5	2	3.5	56	9.96	0.00262366
TIA 90S-8	0.37	2.58	1.49	0.86	2.45	1.42	0.82	2.36	1.37	0.79	710	65	62.2	54.8	0.58	1.7	2.2	1.6	3.2	56	11.38	0.00326564
TIA 90L1-8	0.55	3.84	2.22	1.28	3.65	2.11	1.22	3.52	2.03	1.17	705	65	62.6	55.6	0.58	1.9	2.3	1.7	3.4	56	13.94	0.00428110
*TIA 90L2-8	0.75	4.69	2.71	1.56	4.45	2.57	1.49	4.29	2.48	1.43	700	69	67.5	61.8	0.61	1.8	2.1	1.8	3.5	59	15.50	0.00488424
TIA 100L1-8	0.75	4.43	2.56	1.48	4.21	2.43	1.40	4.06	2.34	1.35	685	68.5	68	62.7	0.65	1.9	2.2	1.8	3.6	59	17.60	0.00634648
TIA 100L2-8	1.1	5.85	3.38	1.95	5.56	3.21	1.85	5.35	3.09	1.79	700	75	75	71.3	0.66	1.8	2.4	1.8	4.2	59	20.00	0.00833992
TIA 112M-8	1.5	7.87	4.54	2.62	7.48	4.32	2.49	7.21	4.16	2.40	700	76	76.5	73.4	0.66	1.8	2.3	1.8	4	61	25.30	0.01395044
TIA 132S-8	2.2	10.6	6.13	3.54	10.1	5.83	3.36	9.73	5.62	3.24	715	79	79	76	0.69	1.9	2.4	1.7	4.9	64	39.60	0.03213071
TIA 132M-8	3	13.7	7.89	4.55	13.0	7.49	4.33	12.5	7.22	4.17	715	81.4	82	80	0.71	2	2.5	1.8	5.1	64	47.40	0.04059848
TIA 160M1-8	4	18.3	10.6	6.11	17.4	10.1	5.81	16.8	9.70	5.60	715	82	82.6	80.7	0.7	1.8	2.3	1.6	4.6	68	59.80	0.07103601
TIA 160M2-8	5.5	24.8	14.3	8.25	23.5	13.6	7.84	22.7	13.1	7.56	710	83.5	84.4	83.1	0.7	1.9	2.4	1.8	4.8	68	69.00	0.08622631
TIA 160L-8	7.5	33.0	19.0	11.0	31.3	18.1	10.4	30.2	17.4	10.1	715	85.5	86	84.5	0.7	2.5	2.8	2	5.7	68	84.80	0.11307620

*Motores de carcasa reducida

SERIE T3A

MOTORES ASÍNCRONOS TRIFÁSICOS - 1 VELOCIDAD - CARCASA DE ALUMINIO - CLASE DE EFICIENCIA IE3

Carcasa 63-160; Polos 2-4-6.

2 POLOS - 3000 RPM - 50 HZ - 3600 RPM - 60 HZ

Tipo	Potencia	Corriente (A)			Corriente (A)			Corriente (A)			Velocidad (r/min)	Eficiencia			Factor de potencia	Tst/Tn	Tmax/Tn	Tmin/Tn	Ist/In	dB(A)	Peso (kg)	Inercia (kg*m2)
		220V	380V	660V	230V	400V	690V	240V	415V	720V		100%	75%	50%								
T3A 63I-2	0.18	0.96	0.55	0.32	0.91	0.53	0.30	0.88	0.51	0.29	2850	65.9	63.5	56.2	0.75	2	2.5	1.6	4.7	61	3.6	0.00023100
T3A 63S-2	0.25	1.21	0.70	0.40	1.15	0.66	0.38	1.11	0.64	0.37	2840	69.7	68.4	62.5	0.78	2.5	2.7	2	5.2	61	3.9	0.00025500
T3A 71I-2	0.37	1.74	1.00	0.58	1.65	0.95	0.55	1.59	0.92	0.53	2860	73.8	72.4	66.5	0.76	2.5	2.8	1.8	5.6	64	5.2	0.00036900
T3A 71S-2	0.55	2.33	1.34	0.78	2.21	1.28	0.74	2.13	1.23	0.71	2860	77.8	76.5	70.2	0.8	3.1	3.1	2	6.5	64	6.2	0.00049500
*T3A 71S-2	0.75	2.98	1.72	0.99	2.83	1.64	0.94	2.73	1.58	0.91	2870	80.7	80.8	78.2	0.82	3	3.2	2.2	7.1	65	7.1	0.00060600
T3A 80I-2	0.75	3.02	1.74	1.01	2.87	1.66	0.96	2.76	1.60	0.92	2890	80.7	80.3	77.2	0.81	3.1	3.2	2.3	7.4	67	8.9	0.00097215
T3A 80S-2	1.1	4.27	2.46	1.42	4.06	2.34	1.35	3.91	2.26	1.30	2900	82.7	82.5	79.9	0.82	3.2	3.2	2.2	7.8	67	10.6	0.00127539
*T3A 80S-2	1.5	5.79	3.34	1.93	5.50	3.17	1.83	5.30	3.06	1.77	2910	84.2	83.9	81.5	0.81	4	4	2.2	9.6	70	12.5	0.00165443
T3A 90S-2	1.5	5.72	3.30	1.91	5.43	3.14	1.81	5.24	3.02	1.75	2900	84.2	83.8	81.4	0.82	3.5	3.7	2.1	8.3	72	14	0.00218574
T3A 90L1-2	2.2	8.02	4.63	2.67	7.62	4.40	2.54	7.35	4.24	2.45	2910	85.9	86.1	84.7	0.84	3.3	3.7	1.5	9	72	16.3	0.00263595
*T3A 90L2-2	3	11.3	6.54	3.78	10.8	6.21	3.59	10.4	5.99	3.46	2910	87.1	87.1	84.2	0.8	4	4.1	2.6	9.6	74	18.5	0.00340596
T3A 100L1-2	3	10.2	5.88	3.39	9.68	5.59	3.23	9.33	5.38	3.11	2910	87.1	87.5	86.3	0.89	3.2	3.6	2.6	9.4	76	23.7	0.00484163
*T3A 100L2-2	4	13.0	7.50	4.33	12.3	7.12	4.11	11.9	6.87	3.96	2910	88.1	88.8	88.1	0.92	2.8	3.3	2.1	9.1	77	27.6	0.00590710
T3A 112M1-2	4	13.1	7.58	4.38	12.5	7.20	4.16	12.0	6.94	4.01	2920	88.1	88.2	87	0.91	3.4	3.9	2.4	10.5	77	30.1	0.00750510
*T3A 112M2-2	5.5	17.8	10.3	5.94	16.9	9.78	5.65	16.3	9.43	5.44	2920	89.2	89.6	89.1	0.91	3.3	4.2	2.9	11.9	78	35.7	0.00925127
*T3A 112M3-2	7.5	23.8	13.7	7.94	22.6	13.1	7.54	21.8	12.6	7.27	2920	90.1	91.0	90.0	0.92	3.5	3.8	2.1	11.4	80	40	0.01128847
T3A 132S1-2	5.5	18.2	10.5	6.08	17.3	10.0	5.77	16.7	9.64	5.56	2930	89.2	89.4	88.2	0.89	3.2	4	2.5	10	80	43.4	0.01521165
T3A 132S2-2	7.5	23.8	13.7	7.94	22.6	13.1	7.54	21.8	12.6	7.27	2930	90.1	90.9	90.7	0.92	2.6	3.6	1.9	10.1	80	51.7	0.01899607
T3A 132M1-2	9.2	29.4	17.0	9.79	27.9	16.1	9.30	26.9	15.5	8.96	2930	90.6	91.2	90.5	0.91	3.2	4.2	2.6	11.6	81	58.3	0.02161887
*T3A 132M2-2	11	34.5	19.9	11.5	32.8	18.9	10.9	31.6	18.2	10.5	2930	91.2	91.5	91.2	0.92	3.6	4.1	2.4	12.2	83	63.5	0.02414181
T3A 132M3-2	15	47.7	27.6	15.9	45.3	26.2	15.1	43.7	25.2	14.6	2940	91.9	92.1	91.2	0.9	4.9	4.9	2	14.4	86	75	0.02855696
*T3A 160M1-2	11	36.1	20.8	12.0	34.3	19.8	11.4	33.0	19.1	11.0	2960	91.2	91	89.6	0.88	3.2	4	1.4	10.3	86	85.5	0.05961337
T3A 160M2-2	15	48.3	27.9	16.1	45.8	26.5	15.3	44.2	25.5	14.7	2960	91.9	91.5	89.9	0.89	3.9	4.2	1.4	11.4	86	104	0.07675122
T3A 160L1-2	18.5	57.9	33.4	19.3	55.0	31.8	18.3	53.0	30.6	17.7	2950	92.4	92.8	91.8	0.91	3	3	1.5	9.1	86	121	0.09225175
T3A 160L2-2	22	68.6	39.6	22.9	65.2	37.6	21.7	62.8	36.3	20.9	2960	92.7	92.8	92.5	0.91	3.8	4	1.6	12.7	88	132	0.10748540

4 POLOS - 1500 RPM - 50 HZ - 1800 RPM - 60 HZ

Tipo	Potencia	Corriente (A)			Corriente (A)			Corriente (A)			Velocidad (r/min)	Eficiencia			Factor de potencia	Tst/Tn	Tmax/Tn	Tmin/Tn	Ist/In	dB(A)	Peso (kg)	Inercia (kg*m2)
		220V	380V	660V	230V	400V	690V	240V	415V	720V		100%	75%	50%								
T3A 63I-4	0.12	0.70	0.40	0.23	0.66	0.38	0.22	0.64	0.37	0.21	1360	64.8	63.7	57.6	0.7	2.2	2.3	2	3.5	52	3.8	0.00030500
T3A 63S-4	0.18	0.97	0.56	0.32	0.92	0.53	0.31	0.89	0.51	0.30	1400	69.9	69.6	65.4	0.7	2.2	2.5	2.1	4.1	52	4.5	0.00039900
*T3A 63S-4	0.25	1.27	0.73	0.42	1.21	0.70	0.40	1.16	0.67	0.39	1395	75	75.1	71.5	0.69	2.9	3	2.7	4.7	55	5.3	0.00052391
T3A 71I-4	0.25	1.30	0.75	0.43	1.23	0.71	0.41	1.19	0.69	0.40	1410	73.5	73.2	69	0.69	2.3	2.5	2.1	4.5	55	5.8	0.00071700
T3A 71S-4	0.37	1.85	1.07	0.62	1.76	1.02	0.59	1.70	0.98	0.57	1420	77.3	77.1	73.6	0.68	2.8	3	2.5	5.2	55	7	0.00096500
T3A 80I-4	0.55	2.80	1.62	0.93	2.66	1.54	0.89	2.56	1.48	0.85	1440	80.8	79.9	76	0.64	3.1	3.3	2.4	6.2	57	9.5	0.00169042
T3A 80S-4	0.75	3.47	2.00	1.16	3.29	1.90	1.10	3.17	1.83	1.06	1440	82.5	82.5	80.1	0.69	3.1	3.1	2.5	6.3	58	11.7	0.00228457
*T3A 80S-4	1.1	4.65	2.69	1.55	4.42	2.55	1.47	4.26	2.46	1.42	1430	84.1	84.9	83.7	0.74	3	3.1	2.6	6.6	61	13.8	0.00299754
T3A 90S-4	1.1	4.65	2.69	1.55	4.42	2.55	1.47	4.26	2.46	1.42	1440	84.1	84.1	81.8	0.74	3.7	3.8	3.1	7.7	61	15.1	0.00384181
T3A 90L1-4	1.5	6.34	3.66	2.11	6.02	3.48	2.01	5.80	3.35	1.93	1440	85.3	85.3	83.1	0.73	4.1	4.1	3.4	8.1	61	18	0.00468546
T3A 100L1-4	2.2	8.14	4.70	2.71	7.74	4.47	2.58	7.46	4.31	2.49	1450	86.7	87.2	86.2	0.82	2.9	3.5	2.4	8	64	23.9	0.00875401
T3A 100L2-4	3	11.5	6.66	3.85	11.0	6.33	3.65	10.6	6.10	3.52	1450	87.7	88	86.9	0.78	3.3	3.4	2.7	8.1	64	28.3	0.01106275
T3A 112M1-4	4	14.5	8.37	4.83	13.8	7.95	4.59	13.3	7.66	4.42	1450	88.6	88.8	88.2	0.82	3.1	3.7	2.6	8.6	65	33.9	0.01529165
*T3A 112M2-4	5.5	20.2	11.7	6.73	19.2	11.1	6.39	18.5	10.7	6.16	1450	89.6	89.9	89.1	0.8	3.8	3.7	2.5	9.1	71	39.1	0.04875837
T3A 132S-4	5.5	19.2	11.1	6.41	18.3	10.5	6.09	17.6	10.2	5.87	1460	89.6	89.8	89.4	0.84	2.3	3.5	1.9	9	71	47.4	0.03446419
T3A 132M1-4	7.5	26.0	15.0	8.66	24.7	14.3	8.23	23.8	13.7	7.93	1460	90.4	90.9	90.3	0.84	2.6	3.4	2.2	8.9	71	57.4	0.04359680
T3A 132M2-4	9.2	32.5	18.8	10.8	30.9	17.8	10.3	29.8	17.2	9.93	1460	90.8	91.3	90.7	0.82	3.2	3.6	2	10	74	60	0.05133916
*T3A 132M3-4	11	37.7	21.8	12.6	35.8	20.7	11.9	34.5	19.9	11.5	1460	91.4	92	91.6	0.84	3.5	3.7	2.1	10.5	75	67	0.06037189
T3A 160M-4	11	38.2	22.0	12.7	36.3	20.9	12.1	34.9	20.2	11.6	1470	91.4	91.7	89.8	0.83	2.6	2.8	1.8	7.6	75	89	0.10537280
T3A 160L1-4	15	50.4	29.1	16.8	47.9	27.7	16.0	46.2	26.7	15.4	1470	92.1	92.3	91.3	0.85	3	3	2	9.2	75	110.5	0.13703810

*Motores de carcasa reducida

6 POLOS - 1000 RPM - 50 HZ - 1200 RPM - 60 HZ

Tipo	Potencia	Corriente (A)			Corriente (A)			Corriente (A)			Velocidad (r/min)	Eficiencia			Factor de potencia	Tst/Tn	Tmax/Tn	Tmin/Tn	Ist/In	dB(A)	Peso (kg)	Inercia (kg*m2)
		220V	380V	660V	230V	400V	690V	240V	415V	720V		100%	75%	50%								
T3A 711-6	0.18	1.20	0.69	0.40	1.14	0.66	0.38	1.09	0.63	0.36	930	63.9	61	53.4	0.62	2.4	2.6	2.3	3.5	52	5.4	0.00079000
T3A 712-6	0.25	1.48	0.85	0.49	1.40	0.81	0.47	1.35	0.78	0.45	920	68.6	67.2	61.2	0.65	2.2	2.5	2.2	3.7	52	6.3	0.00102000
T3A 801-6	0.37	1.95	1.12	0.65	1.85	1.07	0.62	1.78	1.03	0.59	930	73.5	73.8	70.5	0.68	2.2	2.5	2.1	4.1	56	9.3	0.00218934
T3A 802-6	0.55	2.64	1.52	0.88	2.51	1.45	0.84	2.42	1.40	0.81	930	77.2	78.1	75.7	0.71	2.3	2.4	2.1	4.3	56	10.9	0.00293059
*T3A 803-6	0.75	3.97	2.29	1.32	3.77	2.18	1.26	3.64	2.10	1.21	935	78.9	78.2	74.4	0.63	2.8	3.1	2.6	4.9	59	12.5	0.00322709
T3A 90S-6	0.75	3.73	2.16	1.24	3.55	2.05	1.18	3.42	1.97	1.14	950	78.9	80.1	78.1	0.67	2.3	2.6	2.1	4.7	59	13.8	0.00406984
T3A 90L-6	1.1	5.33	3.08	1.78	5.07	2.93	1.69	4.88	2.82	1.63	950	81	81.1	78.4	0.67	2.7	2.9	2.5	5.2	59	16.2	0.00548739
*T3A 90L2-6	1.5	7.14	4.12	2.38	6.78	3.92	2.26	6.54	3.78	2.18	950	82.5	82.7	80.5	0.67	2.9	3	2.5	5.6	61	21.3	0.00689472
T3A 100L1-6	1.5	6.84	3.95	2.28	6.49	3.75	2.16	6.26	3.61	2.09	955	82.5	83	81.8	0.7	2.4	2.9	2.2	5.5	61	22.1	0.00913729
*T3A 100L2-6	2.2	9.54	5.51	3.18	9.06	5.23	3.02	8.73	5.04	2.91	955	84.3	85.1	83.9	0.72	2.5	3	2.2	6.2	64	27.7	0.01272548
T3A 112M1-6	2.2	10.1	5.83	3.37	9.59	5.54	3.20	9.25	5.34	3.08	965	84.3	84.5	83.2	0.68	2	2.5	1.9	5.5	64	27.1	0.01767543
*T3A 112M2-6	3	13.4	7.72	4.46	12.7	7.33	4.23	12.2	7.07	4.08	965	85.6	86.2	84.8	0.69	2.5	2.9	1.9	6.3	64	33.1	0.02140041
T3A 132S-6	3	12.5	7.20	4.15	11.8	6.84	3.95	11.4	6.59	3.80	965	85.6	86	85.1	0.74	2	2.7	1.7	6	64	38.6	0.03380429
T3A 132M1-6	4	16.4	9.46	5.46	15.6	8.99	5.19	15.0	8.66	5.00	970	86.8	87.1	86.2	0.74	2.3	3	1.8	6.8	68	47.6	0.04394565
T3A 132M2-6	5.5	23.2	13.4	7.72	22.0	12.7	7.34	21.2	12.2	7.07	975	88	88.3	87.1	0.71	2.9	3.5	2.2	7.4	68	55.7	0.05398713
*T3A 132M3-6	7.5	30.8	17.8	10.3	29.2	16.9	9.74	28.2	16.3	9.39	970	89.1	89.6	88.6	0.72	3.3	3.2	2	8.3	68	67.6	0.07072295
T3A 160M-6	7.5	29.1	16.8	9.72	27.7	16.0	9.23	26.7	15.4	8.90	975	89.1	89.5	88.5	0.76	2.2	2.9	1.8	7.3	68	79.6	0.10901170
T3A 160L-6	11	41.1	23.7	13.7	39.0	22.5	13.0	37.6	21.7	12.5	975	90.3	90.8	89.9	0.78	2.7	2.9	1.2	8.4	73	105	0.15484950

*Motores de carcasa reducida

SERIE T4A

MOTORES ASÍNCRONOS TRIFÁSICOS - 1 VELOCIDAD - CARCASA DE ALUMINIO - CLASE DE EFICIENCIA IE4

Carcasa 63-160; Polos 2-4-6-8.

2 POLOS - 3000 RPM - 50 HZ - 3600 RPM - 60 HZ

Tipo	Potencia	Eficiencia			Factor de potencia (cos φ)	Corriente (A)			Velocidad (r/min)	Tn (Nm)	Tstart/Tn	Tmax/Tn	Tmin/Tn	Ist/In	dB(A)	Peso (kg)	Inercia (kg*m2)
		100%	75%	50%		230V	400V	690V									
T4A63I-2	0.18	70.8	68.8	63.6	0.75	0.85	0.49	0.28	2870	0.624	2.6	2.9	2	5.5	61	3.8	0.000245
T4A63I-2	0.25	74.3	73.1	68.7	0.77	1.1	0.63	0.37	2880	0.8637	2.7	3.2	2.4	6.3	61	4.5	0.000303
T4A71I-2	0.37	78.1	77.3	73.4	0.78	1.52	0.88	0.51	2890	12.739	2.8	3.3	2.3	6.7	64	5.7	0.000421
T4A712-2	0.55	81.5	81.1	77.9	0.79	2.14	1.23	0.71	2890	18.936	2.9	3.5	2.5	6.8	64	6.7	0.000569
T4A80I-2	0.75	83.5	83.6	81.5	0.8	2.82	1.62	0.94	2900	25.733	3.7	3.9	2.5	8.8	67	9.5	0.001124
T4A802-2	1.1	85.2	85.2	83.3	0.82	3.95	2.27	1.32	2910	37.612	4	4.2	2.6	10	67	12	0.001508
T4A90S-2	1.5	86.5	86.5	84.6	0.81	5.37	3.09	1.79	2910	51.289	3.6	2.8	4	9.6	72	14.5	0.002296
T4A90L-2	2.2	88	88.2	86.9	0.83	7.56	4.35	2.52	2900	75.483	4	4.2	3	10.5	72	18.5	0.003086
T4A100L-2	3	89.1	89.4	88.4	0.9	9.39	5.4	3.13	2910	10.258	3.7	2.9	3.9	11	76	28	0.005939
T4A112M-2	4	90	90.4	89.7	0.91	12.3	7.05	4.09	2920	13.63	3.5	2.6	3.9	10.5	77	35	0.00927
T4A132S1-2	5.5	90.9	90.9	89.5	0.9	17.3	9.93	5.63	2940	18.614	3.4	2.3	4	10.5	80	49	0.017735
T4A132S2-2	7.5	91.7	91.7	90.7	0.91	23.1	13.3	7.52	2940	25.383	3.8	2.3	4.1	10	80	59	0.02288
T4A160M1-2	11	92.6	93.2	92.1	0.91	32.6	18.8	10.9	2950	37.102	3.5	2.5	3.8	10	86	95	0.069134
T4A160M2-2	15	93.3	93.8	92.8	0.92	43.9	25.2	14.6	2960	50.422	3.6	2.5	3.8	10	86	116	0.090348
T4A160L-2	18.5	93.7	94.2	93.1	0.93	53.3	30.6	17.8	2960	62.188	3.8	2.5	4	10.3	86	136	0.107485

4 POLOS - 1500 RPM - 50 HZ - 1800 RPM - 60 HZ

Tipo	Potencia	Eficiencia			Factor de potencia (cos φ)	Corriente (A)			Velocidad (r/min)	Tn (Nm)	Tstart/Tn	Tmax/Tn	Tmin/Tn	Ist/In	dB(A)	Peso (kg)	Inercia (kg*m2)
		100%	75%	50%		230V	400V	690V									
T4A63I-4	0.12	69.8	68.2	66.5	0.66	0.65	0.38	0.22	1400	0.8529	2.3	2.7	2.3	4	52	4	0.000336
T4A632-4	0.18	74.7	74.1	69.7	0.67	0.9	0.53	0.3	1400	12.793	2.6	2.8	2.4	4.3	52	4.8	0.00043
T4A71I-4	0.25	77.9	77	72.9	0.65	1.24	0.71	0.41	1430	17.395	3	3.4	2.8	5.6	55	6.5	0.000841
T4A712-4	0.37	81.1	80.5	77.2	0.66	1.74	1	0.58	1430	25.745	3.4	3.6	3	6.2	55	8	0.001188
T4A80I-4	0.55	83.9	83.3	80.6	0.67	2.46	1.41	0.82	1440	38.003	3.4	3.7	3	6.8	57	11	0.002047
T4A802-4	0.75	85.7	85.3	82.8	0.67	3.28	1.97	1.09	1450	51.466	3.7	4	3.1	7.3	58	13	0.002646
*T4A90S-4	1.1	87.2	87.1	84.4	0.69	4.59	2.64	1.53	1435	76.272	4.8	3.8	4.1	8.2	61	18	0.004685
*T4A90L-4	1.5	88.2	88.1	86.1	0.71	6.01	3.46	2	1455	10.258	4.8	3.8	4.2	9.2	61	21.5	0.005696
T4A100L-4	2.2	89.5	89.6	88.2	0.76	8.12	4.67	2.71	1460	14.993	3.5	3	4.3	9.5	64	26	0.010435
*T4A100L2-4	3	90.4	89.7	88.1	0.75	11.1	6.41	3.7	1460	20.445	3.8	3.4	4.5	9.5	64	33	0.013074
*T4A112M-4	4	91.1	91	90	0.8	14	8.08	4.59	1460	27.26	4	3	4.5	9.8	65	41	0.019436
T4A132S-4	5.5	91.9	92.2	91.5	0.8	18.8	10.9	6.26	1470	37.228	3.4	2.1	4.1	10	71	56	0.043597
T4A132M-4	7.5	92.6	92.8	92.2	0.81	25.1	13.9	8.37	1470	50.765	4.4	2.2	4	10.2	71	74	0.05521
T4A160M-4	11	93.3	93.5	92.8	0.82	36.1	20.7	12	1475	74.203	2.8	2.2	3.2	9.1	75	100	0.127619
T4A160L-4	15	93.9	94.1	93.7	0.83	48.3	27.9	16.1	1475	101.19	3.2	2.2	3.5	9.2	75	126	0.165297

* Soporte lado ventilador y caperuza protectora más larga del estándar

6 POLOS - 1000 RPM - 50 HZ - 1200 RPM - 60 HZ

Tipo	Potencia	Eficiencia			Factor de potencia (cos Φ)	Corriente (A)			Velocidad (r/min)	Tn (Nm)	Tstart/Tn	Tmax/Tn	Tmin/Tn	Ist/In	dB(A)	Peso (kg)	Inercia (kg*m ²)
		100%	75%	50%		230V	400V	690V									
T4A711-6	0.18	70.1	66.8	60.2	0.6	1.07	0.62	0.36	940	19.053	2.7	2.3	2.9	4.1	52	6.3	0.00102
T4A712-6	0.25	74.1	71.5	65.3	0.6	1.41	0.81	0.47	940	26.463	2.8	2.4	2.9	4.5	52	7.4	0.00125
T4A801-6	0.37	78	76.7	72.2	0.61	1.95	1.12	0.65	950	38.753	2.7	3.1	2.5	4.8	56	11	0.002634
*T4A802-6	0.55	80.9	80	76.3	0.61	2.8	1.61	0.93	950	57.605	3.2	3.5	2.8	5.3	56	14	0.003677
*T4A90S-6	0.75	82.7	81.6	77.7	0.63	3.61	2.08	1.2	960	77.734	2.8	2.4	3.2	5.7	59	15.5	0.004683
*T4A90L-6	1.1	84.5	83.5	80.5	0.65	5.03	2.89	1.68	960	11.401	3.1	2.5	3.3	5.9	59	20	0.006503
T4A100L-6	1.5	85.9	86.2	84.5	0.72	6.09	3.5	2.03	965	15.466	2.7	1.9	3	6.5	61	28	0.012757
T4A112M-6	2.2	87.4	87.2	85.4	0.69	9.16	4.98	3.05	970	22.567	3	2.6	3.8	7.5	64	35	0.02289
T4A132S-6	3	88.6	88.7	87.4	0.71	12	6.88	3.99	975	30.615	2.5	1.9	3.2	7.1	64	47	0.043846
T4A132M1-6	4	89.5	89.8	88.8	0.74	15.2	8.72	5.05	975	40.821	2.8	1.8	3.4	8	68	55	0.053987
T4A132M2-6	5.5	90.5	90.7	89.7	0.75	20.3	11.7	6.78	975	56.128	3.3	1.8	3.3	8.2	68	68	0.070723
T4A160M-6	7.5	91.3	91.5	90.3	0.77	26.7	15.4	8.89	980	76.148	3.3	1.8	3.3	8.5	68	92	0.128267
T4A160L-6	11	92.3	92.6	91.2	0.77	38.9	22.3	12.9	980	111.68	3.4	1.8	3.4	8.5	73	120	0.18523

8 POLOS - 750 RPM - 50 HZ - 900 RPM - 60 HZ

Tipo	Potencia	Eficiencia			Factor de potencia (cos Φ)	Corriente (A)			Velocidad (r/min)	Tn (Nm)	Tstart/Tn	Tmax/Tn	Tmin/Tn	Ist/In	dB(A)	Peso (kg)	Inercia (kg*m ²)
		100%	75%	50%		230V	400V	690V									
T4A712-8	0.12	62.3	59.8	52.6	0.6	0.81	0.47	0.27	690	17.304	2.2	2.3	2	2.9	50	7.5	0.001327
T4A801-8	0.18	67.2	64.1	56.8	0.52	1.29	0.74	0.43	710	25.225	2.3	2.7	2	3.4	52	10	0.002323
T4A802-8	0.25	70.8	67.9	61	0.52	1.7	0.98	0.57	710	35.035	2.7	3.1	2.4	3.7	52	12	0.00308
T4A90S-8	0.37	74.3	71.9	65.7	0.52	2.4	1.38	0.8	715	5.149	2.5	2.2	2.9	3.9	56	14	0.00407
T4A90L-8	0.55	77	75.4	70.1	0.52	3.45	1.98	1.15	710	77.077	2.5	2.2	2.9	4	56	17.5	0.005498
T4A100L1-8	0.75	78.4	77.9	74.4	0.64	3.75	2.16	1.25	710	10.511	2.1	2.1	2.8	4.3	59	20.5	0.00834
T4A100L2-8	1.1	80.8	80.7	78.1	0.64	5.34	3.07	1.78	710	15.415	2.3	1.8	2.6	4.5	59	26	0.011561
T4A112M-8	1.5	82.6	82.3	79.5	0.63	7.24	4.16	2.41	715	20.874	2.5	2.3	3	5.1	61	33	0.0214
T4A132S-8	2.2	84.5	85.5	82.5	0.64	10.2	5.87	3.4	725	30.193	2.3	2	3	5.6	64	50	0.048867
T4A132M-8	3	85.9	86	84.2	0.67	13.1	7.52	4.36	725	41.172	2.5	2.1	3.1	6.3	64	61	0.062355
T4A160M1-8	4	87.1	87.5	86.3	0.69	16.7	9.61	5.57	725	54.9	2.2	1.7	2.8	5.6	68	76	0.101417
T4A160M2-8	5.5	88.3	88.7	87.8	0.7	22.3	12.8	7.45	725	75.483	2.5	1.8	3	6.1	68	94	0.135595
T4A160L-8	7.5	89.3	89.7	89	0.71	29.7	17.1	9.9	725	102.93	2.6	1.6	3	6.6	68	116	0.177635

*Soporte lado ventilador y caperuza protectora más larga del estándar

SERIE TC

MOTORES ASÍNCRONOS TRIFÁSICOS CARCASA DE FUNDICIÓN 'ECOL'

CARACTERÍSTICAS

- Ahorro de energía, alta eficiencia
- Alto par de arranque
- Diseño versátil y fácil de adaptar a una gran variedad de aplicaciones
- Patas desmontables
- Posición caja de bornes arriba, izquierda o derecha
- Eficiencia IE1, IE2, IE3, IE4
- Diseño compacto

APLICACIONES

- > Bombas
- > Plantas de tratamiento de aguas
- > Compresores
- > Ventiladores
- > Reductores
- > Transmisión de potencia
- > Papeleras
- > Cintas transportadoras
- > Sector agrícola
- > Minería
- > Equipos hidráulicos



IE3 e IE4 RAL 7024

DIAGRAMA DE DESPIECE DEL MOTOR CARCASA DE FUNDICIÓN

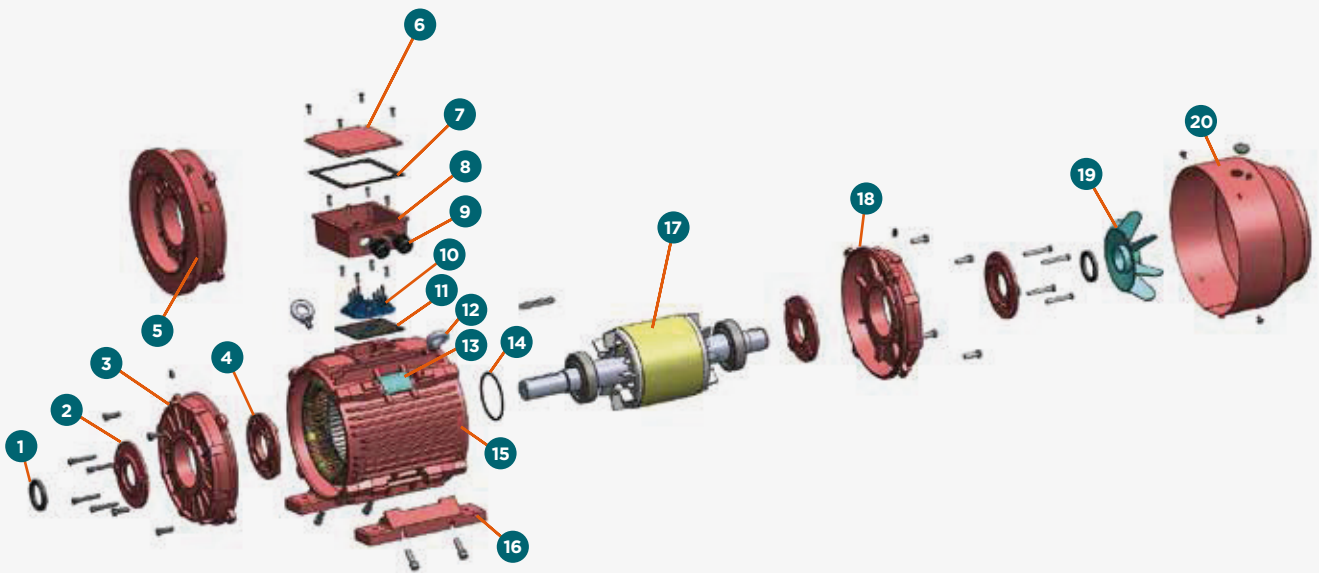

- | | | | |
|--|---------------------------------|----------------------------------|----------------------------|
| 1 Retén | 6 Tapa caja de bornes | 11 Junta inferior caja de bornes | 16 Patas |
| 2 Tapa externa rodamiento lado accionamiento | 7 Junta superior caja de bornes | 12 Cáncamos de sujeción | 17 Rotor |
| 3 Soporte lado accionamiento | 8 Caja de bornes | 13 Placa de características | 18 Soporte lado ventilador |
| 4 Tapa interna rodamiento lado accionamiento | 9 Prensaestopas | 14 Arandela ondulada | 19 Ventilador |
| 5 Brida B5 | 10 Bornera | 15 Carcasa | 20 Caperuza protectora |

MEDIDAS EXTERIORES Y FORMAS CONSTRUCTIVAS

Tipo	B3				Eje						General							
	H	A	B	C	D	E	F	G	K	AA	AD	AH	AC	L	TBS	TBW	TBH	
160M/L	160	254	210/254*	108	Ø42	110	12	37	15	316	404	244	Ø313	605/650*	91	162	187	
180M/L	180	279	241/279*	121	Ø48	110	14	42.5	15	354	445	265	Ø360	687/725*	160/180	162	187	
200L	200	318	305	133	Ø55	110	16	49	19	393	500	300	Ø399	768.5	192	186	233	
225S	4,6,8	225	356	286	149	Ø60	140	18	53	19	440	558	333	Ø459	810	199	186	233
	2	225	356	311	149	Ø55	110	16	49	19	440	558	333	Ø459	805	211.5	186	233
225M	4,6,8	225	356	311	149	Ø60	140	18	53	19	440	558	333	Ø459	835	211.5	186	233
	2	250	406	349	168	Ø60	140	18	53	24	484	616	366	Ø506	915	233	218	260
250M	4,6,8	250	406	349	168	Ø65	140	18	58	24	484	616	366	Ø506	915	233	218	260
	2	280	457	368/419*	190	Ø65	140	18	58	24	560	675	395	Ø559	984/1035*	265/277*	218/245*	260/280*
280S/M	4,6,8	280	457	368/419*	190	Ø75	140	20	67.5	24	560	675	395	Ø559	984/1035*	265/277*	218/245*	260/280*
	2	315	508	406	216	Ø65	140	18	58	Ø28	628	825	510	Ø680	1205	200	290	350
315S	4,6,8	315	508	406	216	Ø80	170	22	71	Ø28	628	825	510	Ø680	1235	200	290	350
	2	315	508	457/508*	216	Ø65	140	18	58	Ø28	628	825	510	Ø680	1355	200	290	350
315M/L	4,6,8	315	508	457/508*	216	Ø80	170	22	71	Ø28	628	825	510	Ø680	1385	200	290	350
	2	355	610	560/630*	254	Ø75	140	20	67.5	Ø28	740	1010	655	Ø820	1495	140	330	380
355M/L	4,6,8	355	610	560/630*	254	Ø95	170	25	86	Ø28	740	1010	655	Ø820	1525	140	330	380
	4,6,8	355	610	560/630*	254	Ø100	210	28	90	Ø28	740	1010	655	Ø820	1565	140	330	380
	2	355	610	560/630*	254	Ø100	210	28	90	Ø28	740	1010	655	Ø820	1565	140	330	380

Tipo	Rodamientos		Prensaestopas	B5						B14					
	DE	NDE		N	M	P	S	T	R	N	M	P	S	T	R
160M/L		6309	2-M32x1.5	Ø250	Ø300	Ø350	4xØ19	5	0	180	215	250	M12	5	0
180M/L		6311	2-M32x1.5	Ø250	Ø300	Ø350	4xØ19	5	0						
200L		6312	2-M40x1.5	Ø300	Ø350	Ø400	4xØ19	5	0						
225S/M		6313	2-M50x1.5	Ø350	Ø400	Ø450	8xØ19	5	0						
250M		6314	2-M50x1.5	Ø450	Ø500	Ø550	8xØ19	5	0						
280S/M		6316	2-M50x1.5	Ø450	Ø500	Ø550	8xØ19	5	0						
315S/M/L	2		6317	2-M63x1.5	Ø550	Ø600	Ø660	8xØ24	6	0					
	4,6,8	NU319	6319												
355M/L	2		6319	2-M63x1.5	Ø680	Ø740	Ø800	8xØ24	6	0					
	4,6,8	NU322	6322												

*Motores de carcasa reducida

IM B3

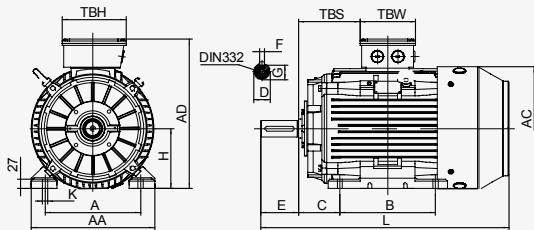

IM B3S

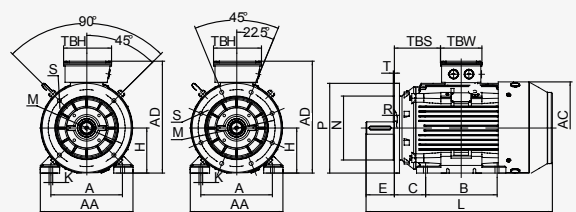

IM B5

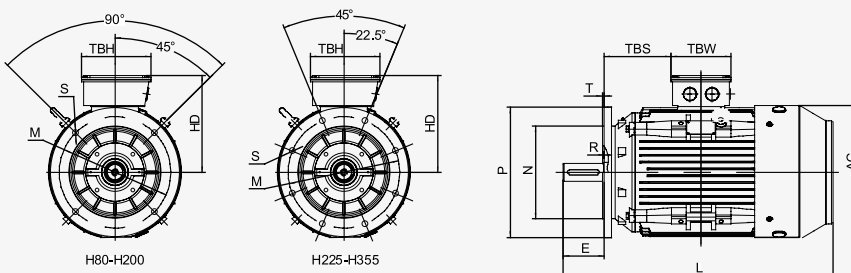

IM B34

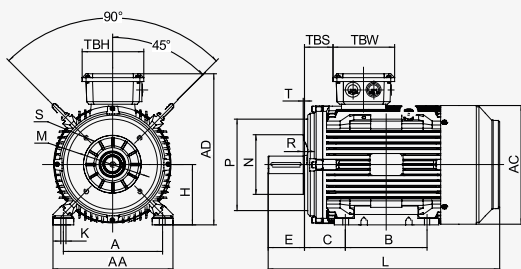

IM B14

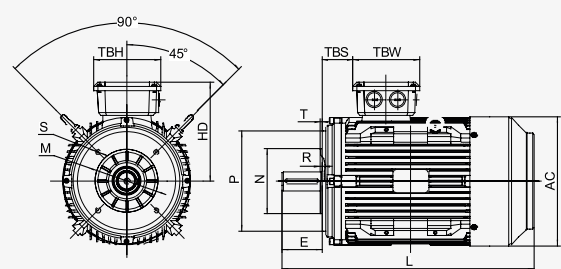

SERIE T3C

MOTORES ASÍNCRONOS TRIFÁSICOS - 1 VELOCIDAD - CARCASA DE FUNDICIÓN - CLASE DE EFICIENCIA IE3

Carcasa 160-355; Polos 2-4-6.

2 POLOS - 3000 RPM - 50 HZ - 3600 RPM - 60 HZ

Tipo	Potencia (kW)	Corriente (A)	Velocidad (r/min)	Eficiencia 100% load (%)	Eficiencia 75% load (%)	Eficiencia 50% load (%)	Factor de potencia (cos φ)	Par nominal (N.m)	Tst/Tn	Tmin/Tn	Tmax/Tn	Ist/In	dB(A)	Peso (kg)	Inercia (kg·m²)
T3C 160M1-2	11	19.34	2930	91.2	93.8	93.0	0.90	35.85	2.5	1.4	3.0	9.5	86	118.0	0.05178
T3C 160M2-2	15	26.18	2940	91.9	93.1	92.9	0.90	48.72	2.5	1.4	3.0	10	86	128.0	0.06206
T3C 160L-2	18.5	31.76	2940	92.4	93.5	93.3	0.91	60.09	2.5	1.4	3.0	9.5	86	144.00	0.07669
*T3C 160L2-2	22	38.5	2945	92.7	93.1	92.2	0.89	71.3	2.5	1.4	3	9.5	86	160	0.09119
T3C 180M-2	22	38.5	2945	92.7	94.1	93.6	0.89	71.34	2.5	1.4	3.0	9	89	183.40	0.09665
*T3C 180L-2	30	52.2	2945	93.3	93.6	92.8	0.89	97.3	2.5	1.4	3	9	89	201	0.12521
T3C 200L1-2	30	52.1	2945	93.3	93.8	93.2	0.89	97.3	2.5	1.5	2.5	8.5	92	247.00	0.17351
T3C 200L2-2	37	64.0	2945	93.7	94.4	94.2	0.89	120.0	2.5	1.5	2.5	8.5	92	268.00	0.20008
*T3C 200L3-2	45	78.5	2930	94	94.3	93.2	0.88	146.7	2.5	1.4	2.5	9	92	285	0.24315
T3C 225M-2	45	75.9	2950	94	94.6	94.1	0.91	145.7	2.5	1.4	2.5	8.5	92	369.00	0.34366
*T3C 225M2-2	55	93.6	2960	94.3	94.5	93.8	0.9	177.4	2.5	1.4	2.5	9	92	402	0.39902
T3C 250M-2	55	93.5	2960	94.3	94.5	93.1	0.90	177.4	2.5	1.4	2.6	10	93	428.00	0.44434
*T3C 250M2-2	75	127	2960	94.7	94.9	93.9	0.9	242.0	2.5	1.4	2.5	9.5	93	462	0.58168
T3C 280S-2	75	125.6	2960	94.7	94.9	93.7	0.91	242.0	2.5	1.8	2.6	10	94	587.30	0.82911
T3C 280M-2	90	150.3	2960	95	95.2	94.3	0.91	290.4	2.5	1.8	2.6	10	94	655.00	0.98168
*T3C 280M2-2	110	185.3	2960	95.2	95.4	94.3	0.9	354.9	2.5	1.4	2.5	9.5	94	720	0.19983
T3C 315S-2	110	185.3	2960	95.2	95.5	94.6	0.90	354.9	2.0	1.4	2.3	7	96	980.00	170.352
T3C 315M-2	132	221.9	2960	95.4	95.5	94.7	0.90	425.9	2.0	1.4	2.3	7	96	1100.00	193.860
T3C 315L1-2	160	267.8	2960	95.8	95.8	94.5	0.90	516.2	2.0	1.4	2.3	7	99	1155.00	219.758
T3C 315L2-2	200	334.8	2960	95.8	96.0	94.7	0.90	645.3	2.0	1.4	2.3	7	99	1260.00	255.368
T3C 355M1-2	220	394.6	2960	95.8	96.2	94.8	0.84	709.8	2.0	1.5	2.3	6.5	103	1590.00	295.585
T3C 355M2-2	250	448.4	2960	95.8	96.2	94.8	0.84	806.6	2.0	1.5	2.3	6.5	103	1650.00	314.272
T3C 355L1-2	280	502.2	2960	95.8	96.2	94.8	0.84	903.4	2.0	1.5	2.3	6.5	103	1715.00	347.911
T3C 355L2-2	315	558.3	2960	95.8	96.2	94.8	0.85	1016.3	2.0	1.5	2.3	6.5	103	1780.00	385.287
**T3C355L3-2	355	590.6	2970	96.4	96.5	95.9	0.9	1141.5	1.3	0.7	2.5	6.5	108	1850	4.342
**T355 1-2	400	665.4	2980	96.4	96.5	95.9	0.9	1281.9	1.3	0.7	2.5	6.5	108	2590	6.714
**T355 2-2	450	748.6	2980	96.4	96.5	95.9	0.9	1442.1	1.3	0.7	2.5	6.5	108	2660	7.552
**T355 3-2	500	831.8	2980	96.4	96.5	95.9	0.9	1602.3	1.3	0.7	2.5	6.5	108	2730	8.391
**T355 4-2	560	921.4	2980	96.4	96.5	95.9	0.91	1794.6	1.3	0.6	2.5	6.5	108	2800	9.400
**T355 5-2	630	1036.5	2980	96.4	96.5	95.9	0.91	2019.0	1.3	0.6	2.5	6.5	108	2870	10.625

4 POLOS - 1500 RPM - 50 HZ - 1800 RPM - 60 HZ

Tipo	Potencia (kW)	Corriente (A)	Velocidad (r/min)	Eficiencia 100% load (%)	Eficiencia 75% load (%)	Eficiencia 50% load (%)	Factor de potencia (cos φ)	Par nominal (N.m)	Tst/Tn	Tmin/Tn	Tmax/Tn	Ist/In	dB(A)	Peso (kg)	Inercia (kg·m²)
T3C 160M-4	11	20.68	1450	91.4	92.2	91.7	0.84	72.45	2.5	1.3	3.0	10	75	127.00	0.10355
T3C 160L-4	15	27.33	1450	92.1	92.9	92.2	0.86	98.8	2.5	1.3	2.8	8.5	75	160.00	0.13750
*T3C 160L2-4	18.5	33.5	1460	92.6	93	92.1	0.86	121.0	2.5	1.3	2.8	9.5	75	156	0.16111
T3C 180M-4	18.5	33.5	1460	92.6	93.6	93.0	0.86	121.0	2.5	1.8	3.0	9	76	169.40	0.15530
T3C 180L-4	22	39.2	1460	93	93.7	92.9	0.87	143.9	2.5	1.8	3.0	10	76	196.00	0.19433
*T3C 180L2-4	30	57.1	1470	93.6	94	93.1	0.81	194.9	2.5	1.5	3	9.5	76	211	0.23324
T3C 200L-4	30	57.1	1470	93.6	93.7	93.2	0.81	194.9	2.5	1.8	2.8	9	79	252.00	0.29441
*T3C 200L2-4	37	70.2	1470	93.9	94.2	93.2	0.81	240.4	2.5	1.5	2.8	9	79	272	0.35328
T3C 225S-4	37	65.4	1470	93.9	95.2	94.3	0.87	240.4	2.5	1.4	2.5	9.2	81	324.50	0.57838
T3C 225M-4	45	79.3	1470	94.2	95.2	94.5	0.87	292.3	2.5	1.5	2.5	9	81	352.90	0.65309
*T3C 225M2-4	55	95.4	1470	94.6	94.9	94.1	0.88	357.3	2.5	1.5	2.5	9	81	382	0.79815
T3C 250M-4	55	95.4	1470	94.6	95.2	94.5	0.88	357.3	2.5	1.8	2.5	8.5	83	427.40	0.76504
*T3C 250M2-4	75	131	1480	95	95.1	94.6	0.87	484.0	2.5	1.5	2.5	9	83	470	0.95612
T3C 280S-4	75	131.0	1480	95	95.1	94.8	0.87	484.0	2.5	1.8	2.8	10	86	673.30	199.603
T3C 280M-4	90	160.5	1480	95.2	95.1	95.0	0.85	580.7	2.5	1.8	2.8	10	86	692.00	218.345
*T3C 280M2-4	110	190	1480	95.4	95.7	94.6	0.88	709.8	2.5	1.5	2.5	9.5	86	760	2.66841
T3C 315S-4	110	189.1	1480	95.4	95.7	94.6	0.88	709.8	2.2	1.5	2.6	9	93	1027.00	371.808
T3C 315M-4	132	226.5	1480	95.6	95.8	95.0	0.88	851.8	2.2	1.5	2.6	9	93	1155.00	429.667
T3C 315L1-4	160	273.9	1480	95.8	96.0	95.1	0.88	1032.4	2.2	1.5	2.6	9	97	1240.00	510.990
T3C 315L2-4	200	337.9	1480	96	96.2	95.3	0.89	1290.5	2.2	1.5	2.6	9	97	1400.00	617.334
T3C 355M1-4	220	371.7	1480	96	96.2	95.3	0.89	1419.6	2.0	1.3	2.3	8	101	1560.00	704.227
T3C 355M2-4	250	422.3	1480	96	96.3	95.4	0.89	1613.2	2.0	1.3	2.3	8	101	1600.00	763.820
T3C 355L1-4	280	473.0	1480	96	96.4	95.4	0.89	1806.8	2.0	1.3	2.3	8	101	1650.00	831.927
T3C 355L2-4	315	532.1	1480	96	96.3	95.5	0.89	2032.6	2.0	1.3	2.3	8	101	1700.00	934.080
**T3C355L3-4	355	604.6	1480	96.3	96.4	95.8	0.88	2290.7	1.6	0.8	2.5	6.5	105	1750.00	10.526
**T3C355L4-4	400	681.3	1480	96.3	96.4	95.8	0.88	2581.1	1.6	0.8	2.5	6.5	105	1800.00	11.860
**T355 1-4	450	766.4	1480	96.3	96.4	95.8	0.88	2903.7	1.6	0.7	2.5	6.5	105	2730.00	14.860
**T355 2-4	500	850.7	1480	96.4	96.5	95.9	0.88	3226.4	1.6	0.7	2.5	6.5	105	2805.00	16.510
**T355 3-4	560	942.1	1480	96.4	96.5	95.9	0.89	3613.5	1.6	0.7	2.5	6.5	105	2875.00	18.500
**T355 4-4	630	1058.7	1480	96.5	96.6	96	0.89	4065.2	1.6	0.7	2.5	6.5	105	2945.00	20.100
**T355 5-4	710	1193.2	1480	96.5	96.6	96	0.89	4581.4	1.6	0.7	2.5	6.5	105	2945.00	22.650

*Motores de carcasa reducida

**Motores de alta potencia

6 POLOS - 1000 RPM - 50 HZ - 1200 RPM - 60 HZ

Tipo	Potencia (kW)	Corriente (A)	Velocidad (r/min)	Eficiencia 100% load (%)	Eficiencia 75% load (%)	Eficiencia 50% load (%)	Factor de potencia (cos φ)	Par nominal (N.m)	Tst/Tn	Tmin/Tn	Tmax/Tn	Ist/In	dB(A)	Peso (kg)	Inercia (kg·m ²)
T3C 160M-6	7.5	16.2	960	89.1	90.3	88.0	0.75	74.6	2.3	1.4	2.8	7.5	73	112.00	0.08726
T3C 160L-6	11	23.1	960	90.3	91.2	88.5	0.76	109.4	2.5	1.4	2.8	8.5	73	134.00	0.13544
*T3C 160L2-6	15	31.3	960	91.2	91.8	90.4	0.76	149.2	2.5	1.4	2.8	9	73	152	0.16252
T3C 180L-6	15	30.1	960	91.2	92.0	90.3	0.79	149.2	2.5	1.4	2.8	8	73	184.50	0.27973
*T3C 180L2-6	18.5	36.4	970	91.7	92	91.2	0.8	182.1	2.5	1.4	2.8	9	73	203	0.74406
T3C 200L1-6	18.5	36.4	970	91.7	92.3	90.6	0.80	182.1	2.5	1.4	2.8	9.5	76	231.00	0.38345
T3C 200L2-6	22	42.5	970	92.2	93.0	91.3	0.81	216.6	2.5	1.5	2.8	10	76	249.00	0.44941
*T3C 200L3-6	30	57.6	975	92.9	93.2	92.3	0.81	293.8	2.5	1.4	2.8	9.5	76	273	0.61283
T3C 225M-6	30	53.0	975	92.9	93.8	90.9	0.88	293.8	1.8	1.5	2.2	7	76	339.00	0.67058
T3C 250M-6	37	67.3	975	93.3	94.0	91.8	0.85	362.4	1.8	1.3	2.0	7	78	399.40	0.99243
T3C 280S-6	45	83.5	980	93.7	94.6	92.7	0.83	438.5	2.5	1.8	2.8	10	80	551.00	220.274
T3C 280M1-6	55	99.3	980	94.1	95.0	93.4	0.85	536.0	2.5	1.8	2.8	10	80	624.30	257.302
T3C 315S-6	75	139.6	980	94.6	94.8	93.2	0.82	730.9	2.0	1.3	2.3	7.5	85	860.00	380.317
T3C 315M-6	90	166.9	980	94.9	95	93.4	0.82	877.0	2.0	1.3	2.3	7.5	85	970.00	445.274
T3C 315L1-6	110	203.6	980	95.1	95.4	94	0.82	1071.9	2.0	1.3	2.3	7.5	85	1070.00	553.956
T3C 315L2-6	132	243.6	980	95.4	95.7	94.2	0.82	1286.3	2.0	1.3	2.3	7.5	85	1196.00	662.638
T3C 355M1-6	160	294.6	980	95.6	95.8	94.3	0.82	1559.2	2.0	1.3	2.3	7.5	92	1537.00	897.637
T3C 355M2-6	200	367.5	980	95.8	95.8	94.3	0.82	1949.0	2.0	1.3	2.3	7.5	92	1720.00	1100.175
T3C 355L1-6	220	404.2	980	95.8	96	94.2	0.82	2143.9	2.0	1.3	2.3	7.5	92	1800.00	1164.134
T3C 355L-6	250	459.3	980	95.8	96	94.3	0.82	2436.2	2.0	1.3	2.3	7.5	92	1880.00	1356.011
**T355L-6	250	459.3	980	95.8	95.9	95.3	0.82	2436.2	2	1.3	2.3	7.5	92	1880,00	13,560
**T3C355 L4-6	300	551,2	980	95,8	95,9	95,3	0,82	2923,5	1,8	0,8	2,5	6,5	102	1980,00	16,270
**T355 1-6	315	577,6	980	96	96,1	95,5	0,82	3069,6	1,8	0,8	2,5	6,5	102	2800,00	14,530
**T355 2-6	355	650,9	980	96	96,1	95,5	0,82	3459,4	1,8	0,8	2,5	6,5	102	2850,00	16,375
**T355 3-6	400	731,9	980	96,2	96,3	95,7	0,82	3898,0	1,6	0,8	2,5	6,5	102	2930,00	18,650
**T355 4-6	450	823,4	980	96,2	96,3	95,7	0,82	4385,2	1,6	0,8	2,5	6,5	102	3000,00	20,980

8 POLOS - 750 RPM - 50 HZ - 900 RPM - 60 HZ

Tipo	Potencia (kW)	Corriente (A)	Velocidad (r/min)	Eficiencia 100% load (%)	Eficiencia 75% load (%)	Eficiencia 50% load (%)	Factor de potencia (cos φ)	Par nominal (N.m)	Tst/Tn	Tmin/Tn	Tmax/Tn	Ist/In	dB(A)	Peso (kg)	Inercia (kg·m ²)
T3C 160M1-8	4	10,47	730	84,8	85,1	84	0,65	52,3	1,9	1,2	2,1	6	68	115	0,08001
T3C 160M2-8	5,5	14,17	730	86,2	86,5	85,9	0,65	72,0	2	1,2	2,2	6	68	131	0,09550
T3C 160L-8	7,5	19,08	730	87,3	87,5	86,8	0,65	98,1	1,9	1,2	2,2	6	68	143	0,11123
T3C 180L-8	11	23,89	730	88,6	88,9	88,1	0,75	143,9	2	1,2	2	6,6	70	179	0,26980
T3C 200L-8	15	29,47	730	89,6	90	89,2	0,82	196,2	2	1,2	2	6,6	73	231	0,37954
T3C 225S-8	18,5	37,05	735	90,1	90,4	89,5	0,8	240,4	1,9	1	2	6,6	73	309	0,51532
T3C 225M-8	22	43,81	735	90,6	90,8	90	0,8	285,9	1,9	1	2	6,6	73	339	0,61829
T3C 250M-8	30	59,28	735	91,3	91,5	90,8	0,8	389,8	1,9	1	2	6,6	75	420	1,07109
T3C 280S-8	37	74,58	740	91,8	92	91,3	0,78	477,5	1,9	1	2	6,6	76	549	1,98428
T3C 280M-8	45	90,32	740	92,2	92,3	91,8	0,78	580,7	1,9	1	2	6,6	76	603	2,37308
T3C 315S-8	55	107,28	740	92,5	92,6	92	0,8	709,8	1,8	1	2	6,6	82	903	4,08842
T3C 315M-8	75	145,35	740	93,1	93,3	92,6	0,8	967,9	1,8	1	2	6,6	82	1071	5,53125
T3C 315L1-8	90	173,85	740	93,4	93,5	92,8	0,8	1161,5	1,8	1	2	6,6	82	1155	6,57731
T3C 315L2-8	110	211,81	740	93,7	93,8	93	0,8	1419,6	1,8	1	2	6,4	82	1260	7,81357
T3C 355M1-8	132	253,36	740	94	94,1	93,3	0,8	1703,5	1,8	1	2	6,4	90	1585	9,31327
T3C 355M2-8	160	306,12	740	94,3	94,5	93,8	0,8	2064,9	1,8	1	2	6,4	90	1650	10,54448
T3C 355L-8	200	381,44	740	94,6	94,5	94	0,8	2581,1	1,8	1	2	6,4	90	1830	12,89498

* Motores de carcasa reducida

**Motores de alta potencia

SERIE T4C

MOTORES ASÍNCRONOS TRIFÁSICOS - 1 VELOCIDAD - CARCASA DE FUNDICIÓN - CLASE DE EFICIENCIA IE4

Carcasa 160-355; Polos 2-4-6-8.

2 POLOS - 3000 RPM - 50 HZ - 3600 RPM - 60 HZ

Tipo	Potencia (kW)	Corriente (A)	Velocidad (r/min)	Eficiencia 100% load (%)	Eficiencia 75% load (%)	Eficiencia 50% load (%)	Factor de potencia (cos ϕ)	Par nominal (N.m)	Tst/Tn	Tmin/Tn	Tmax/Tn	Ist/In	dB(A)	Peso (kg)	Inercia (kg·m ²)
T4C 160M1-2	11	19.27	2960	92.6	92.8	92.5	0.89	35.5	2	1.2	2.3	9.5	81	129	0.0695
T4C 160M2-2	15	26.07	2960	93.3	93.5	93.1	0.89	48.42	2	1.2	2.3	9.5	81	155	0.0848
T4C 160L-2	18.5	32.02	2965	93.7	93.9	93.6	0.89	59.6	2	1.1	2.3	9.5	81	176	0.102
T4C 180M-2	22	37.96	2965	94	94.2	93.8	0.89	70.9	2	1.1	2.3	9.5	83	220	0.163
T4C 200L1-2	30	51.48	2970	94.5	94.7	94.3	0.89	96.5	2	1.1	2.3	9	84	278	0.267
T4C 200L2-2	37	63.30	2970	94.8	95	94.7	0.89	119	2	1.1	2.3	9	84	292	0.303
T4C 225M-2	45	76.82	2975	95	95.2	94	0.89	144.5	2	1	2.3	9	86	387	0.393
T4C 250M-2	55	93.60	2980	95.3	95.5	94.3	0.89	176.3	2	1	2.3	9	89	531	1.044
T4C 280S-2	75	127.23	2980	95.6	95.8	95	0.89	240.46	1.8	0.9	2.3	8.5	91	625	1.267
T4C 280M-2	90	152.36	2980	95.8	95.9	95.2	0.89	288.55	1.8	0.9	2.3	8.5	91	700	1.495
T4C 315S-2	110	185.83	2980	96	96.1	95.6	0.89	352.67	1.8	0.9	2.3	8.5	92	1110	2.036
T4C 315M-2	132	222.53	2980	96.2	96.2	95.7	0.89	423.2	1.8	0.9	2.3	8.5	92	1228	2.352
T4C 315L1-2	160	269.45	2980	96.3	96.3	95.8	0.89	513	1.8	0.9	2.2	8.5	92	1321	2.720
T4C 315L2-2	200	336.12	2980	96.5	96.5	96	0.89	641.2	1.8	0.8	2.2	8.5	92	1450	3.273
T4C 355M-2	250	420.15	2980	96.5	96.5	96	0.89	801.5	1.6	0.8	2.2	8.5	97	1700	4.481
T4C 355L-2	315	529.39	2980	96.5	96.5	96	0.89	1009.9	1.6	0.8	2.2	8.5	97	2030	5.604

4 POLOS - 1500 RPM - 50 HZ - 1800 RPM - 60 HZ

Tipo	Potencia (kW)	Corriente (A)	Velocidad (r/min)	Eficiencia 100% load (%)	Eficiencia 75% load (%)	Eficiencia 50% load (%)	Factor de potencia (cos ϕ)	Par nominal (N.m)	Tst/Tn	Tmin/Tn	Tmax/Tn	Ist/In	dB(A)	Peso (kg)	Inercia (kg·m ²)
T4C 160M-4	11	20.50	1475	93.3	93.5	92.8	0.83	71.25	2	1.4	2.3	9.5	73	160	0.144
T4C 160L-4	15	27.45	1475	93.9	94.1	92.8	0.84	97.16	2	1.4	2.3	9.5	73	179	0.184
T4C 180M-4	18.5	33.35	1475	94.2	94.4	93.6	0.85	119.83	2	1.2	2.3	9.5	76	218	0.266
T4C 180L-4	22	39.53	1475	94.5	94.7	93.8	0.85	142.5	2	1.2	2.3	9.5	76	249	0.303
T4C 200L-4	30	53.68	1480	94.9	95.2	94	0.85	193.67	2	1.2	2.3	9	76	295	0.566
T4C 225S-4	37	66.00	1480	95.2	95.4	94.6	0.85	238.85	2	1.2	2.3	9	78	403	0.794
T4C 225M-4	45	80.10	1480	95.4	95.6	95	0.85	290.5	2	1.1	2.3	9	78	425	0.869
T4C 250M-4	55	96.46	1480	95.7	95.9	95.3	0.86	355	2	1.1	2.3	9	79	550	1.435
T4C 280S-4	75	129.61	1485	96	96.1	95.4	0.87	482.5	2	1	2.3	8.5	80	644	2.149
T4C 280M-4	90	153.61	1485	96.1	96.1	95.8	0.88	579	2	1	2.3	8.5	80	714	2.377
T4C 315S-4	110	185.25	1485	96.3	96.3	95.9	0.89	707.7	1.8	1	2.2	8.5	88	1130	3.943
T4C 315M-4	132	222.07	1485	96.4	96.4	96.2	0.89	849.3	1.8	1	2.2	8.5	88	1260	4.471
T4C 315L1-4	160	265.63	1485	96.6	96.6	96.3	0.9	1029.4	1.8	1	2.2	8.5	88	1377	5.267
T4C 315L2-4	200	331.70	1485	96.7	96.7	96.3	0.9	1286.8	1.8	0.9	2.2	8.5	88	1558	6.291
T4C 355M-4	250	414.62	1485	96.7	96.7	96.3	0.9	1608.4	1.8	0.9	2.2	8.5	92	1740	10.212
T4C 355L-4	315	522.42	1485	96.7	96.7	96.4	0.9	2026.6	1.8	0.8	2.2	8.5	92	1933	11.374

6 POLOS - 1000 RPM - 50 HZ - 1200 RPM - 60 HZ

Tipo	Potencia (kW)	Corriente (A)	Velocidad (r/min)	Eficiencia 100% load (%)	Eficiencia 75% load (%)	Eficiencia 50% load (%)	Factor de potencia (cos φ)	Par nominal (N.m)	Tst/Tn	Tmin/Tn	Tmax/Tn	Ist/In	dB(A)	Peso (kg)	Inercia (kg·m²)
T4C 160M-6	7.5	15.60	970	91.3	91.5	91.2	0.76	73.9	2	1.3	2.1	8	73	145	0.149
T4C 160L-6	11	22.34	975	92.3	92.5	92.2	0.77	107.8	2	1.2	2.1	8.5	73	185	0.220
T4C 180L-6	15	29.13	975	92.9	93.2	92.8	0.8	147	2	1.2	2.1	8.5	73	226	0.363
T4C 200L1-6	18.5	35.74	975	93.4	93.6	93.3	0.8	181.3	2	1.2	2.1	8.5	73	246	0.467
T4C 200L2-6	22	41.84	975	93.7	93.9	93.6	0.81	215.6	2	1.2	2.1	8.5	73	271	0.568
T4C 225M-6	30	56.06	980	94.2	94.4	94	0.82	292.5	2	1.2	2.1	8.3	74	351	0.938
T4C 250M-6	37	68.09	980	94.5	94.7	94.3	0.83	360.7	2	1.2	2.1	8.3	76	430	1.633
T4C 280S-6	45	82.55	985	94.8	95	94.7	0.83	436.5	2	1.1	2	8.5	78	533	2.336
T4C 280M1-6	55	99.38	985	95.1	95.3	95	0.84	533.5	2	1.1	2	8.5	78	610	2.703
T4C 315S-6	75	135.09	990	95.4	95.6	95.3	0.84	723.8	1.6	1	2	8	83	1020	4.414
T4C 315M-6	90	159.86	990	95.6	95.8	95.4	0.85	868.6	1.6	1	2	8	83	1212	5.257
T4C 315L1-6	110	194.98	990	95.8	96	95.6	0.85	1061.6	1.6	1	2	8	83	1277	6.309
T4C 315L2-6	132	230.77	990	96	96.2	95.9	0.86	1273.9	1.6	1	2	8	83	1400	7.511
T4C 355M1-6	160	279.14	990	96.2	96.3	96	0.86	1544.1	1.6	1	2	8	85	1740	12.140
T4C 355M2-6	200	348.57	990	96.3	96.3	96.1	0.86	1930.1	1.6	0.9	2	8	85	1893	15.037
T4C 355L-6	250	434.80	990	96.5	96.5	96.4	0.86	2412.7	1.6	0.9	2	8	85	2008	16.968

8 POLOS - 750 RPM - 50 HZ - 900 RPM - 60 HZ

Tipo	Potencia (kW)	Corriente (A)	Velocidad (r/min)	Eficiencia 100% load (%)	Eficiencia 75% load (%)	Eficiencia 50% load (%)	Factor de potencia (cos φ)	Par nominal (N.m)	Tst/Tn	Tmin/Tn	Tmax/Tn	Ist/In	dB(A)	Peso (kg)	Inercia (kg·m²)
T4C 160M1-8	4	9.34	725	87.1	87.3	86.9	0.71	52.7	1.8	1.2	2	7.9	68	117	0.0910
T4C 160M2-8	5.5	12.49	730	88.3	88.5	88.2	0.72	72	1.8	1.2	2	8.1	68	138	0.118
T4C 160L-8	7.5	16.38	730	89.3	89.5	89	0.74	98.2	1.8	1.2	2	7.8	68	161	0.171
T4C 180L-8	11	23.73	735	90.4	90.6	90	0.74	143	1.8	1.1	2	7.9	70	188	0.289
T4C 200L-8	15	31.65	735	91.2	91.4	91	0.75	195	1.8	1.1	2	8	73	220	0.417
T4C 225S-8	18.5	38.83	735	91.7	91.9	91.4	0.75	240.5	1.8	1.1	2	8.1	73	294	0.698
T4C 225M-8	22	45.37	740	92.1	92.3	92	0.76	284	1.8	1.1	2	8.3	73	319	0.829
T4C 250M-8	30	60.66	740	92.7	92.9	92.6	0.77	387.3	1.8	1.1	2	7.9	75	383	1.393
T4C 280S-8	37	73.54	740	93.1	93.3	93	0.78	477.7	1.8	1.1	2	7.9	76	516	2.155
T4C 280M1-8	45	89.16	740	93.4	93.6	93.3	0.78	581	1.8	1	2	7.9	76	575	2.643
T4C 315S-8	55	105.90	740	93.7	93.9	93.4	0.8	710	1.6	1	2	8.2	82	900	4.179
T4C 315M-8	75	143.65	740	94.2	94.5	94	0.8	968.3	1.6	0.9	2	7.6	82	1068	5.604
T4C 315L1-8	90	169.89	740	94.4	94.6	94.2	0.81	1162	1.6	0.9	2	7.7	82	1158	6.659
T4C 315L2-8	110	206.98	745	94.7	94.9	94.5	0.81	1410.7	1.6	0.9	2	7.7	82	1316	8.331
T4C 355M1-8	132	247.86	745	94.9	95.2	94.8	0.81	1693	1.6	0.9	2	7.7	89	1616	13.896
T4C 355M2-8	160	296.15	745	95.1	95.3	95	0.82	2052	1.6	0.9	2	7.7	89	1794	16.860
T4C 355L-8	200	369.02	745	95.4	95.5	95.2	0.82	2565	1.6	0.9	2	7.8	89	1944	19.825

SERIE ATEX

APLICACIONES

- > Bombas
- > Plantas de tratamiento de aguas
- > Compresores
- > Ventiladores
- > Reductores
- > Transmisión de potencia
- > Papeleras
- > Cintas transportadores
- > Sector agrícola
- > Minería
- > Equipos hidráulicos

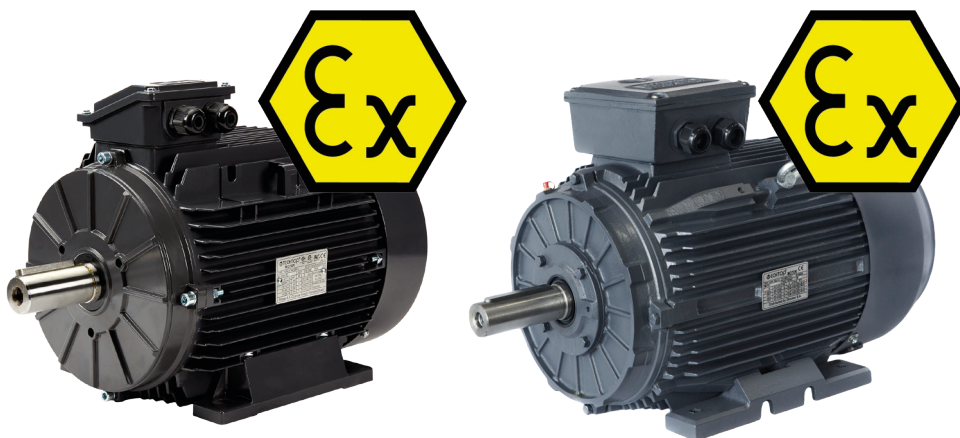

DESGLOSE PLACA DE CARACTERÍSTICAS ATEX ZONA 2-22

TECHTOP [®] MOTOR		II 3 G Ex nA IIC T4 Gc		CE		
TÜV 12 ATEX 111822 X		II 3 D Ex tc IIIC T125°C DC				
TYPE: T1A 802-4		S1 - 100%		IEC60034		
SN No. 2001042041		ThCl. F	IP55	2020	IM B5	KGS
V	Hz	min ⁻¹	kW	A	cos φ	Eff.
230 Δ	50	1390	0.75	3.21	0.79	IE1 74.4%
400 Y	50	1390	0.75	1.85	0.79	IE1 74.4%
276 Δ	60	1390	0.9	3.21	0.79	DE 6204
480 Y	60	1390	0.9	1.85	0.79	NDE 6204
DIMOTOR S.A. C/Corrals Nous, 61 Sabadell (Spain)						

SERIE TA

MEDIDAS EXTERIORES Y FORMAS CONSTRUCTIVAS

Tipo	B3				Eje								General							
	H	A	B	C	D	E	F	G	K	SS	XX	ZZ	AA	AD	HD	AC	L	TBS	TBW	TBH
TA 56	56	90	71	36	Ø9	20	3	7.2	6x9	M4	10	14	112	151	95	Ø110	195	16.5	83	83
TA 63	63	100	80	40	Ø11	23	4	8.5	7x10	M4	10	14	124	172	109	Ø122	217	10	98	98
TA 71	71	112	90	45	Ø14	30	5	11	7x10	M5	12	17	140	189	118	Ø138	245	16	98	98
TA 80	80	125	100	50	Ø19	40	6	15.5	10x15	M6	16	21	160	214	134	Ø157	227/304*	26.5	109	109
TA 90S	90	140	100	56	Ø24	50	8	20	10x15	M8	19	25	176	235	145	Ø177	315/340*	28.5	109	109
TA 90L	90	140	125	56	Ø24	50	8	20	10x15	M8	19	25	176	235	145	Ø177	340/365*	28.5	109	109
TA 100	100	160	140	63	Ø28	60	8	24	12x16	M10	22	30	200	260	160	Ø199	376/411*	32	118	118
TA 112	112	190	140	70	Ø28	60	8	24	12x16	M10	22	30	224	283	171	Ø220	398	33	118	118
TA 132S/M	132	216	140/178	89	Ø38	80	10	33	12x16	M12	28	37	260	323	191	Ø261	460/498	36.5	118	118
TA 160M/L	160	254	210/254	108	Ø42	110	12	37	15x21	M16	36	45	314	391	231	Ø314	616/660	64	148	148

Tipo	KK	B5						B14						B5R						B14B					
		N	M	P	S	T	R	N	M	P	S	T	R	N	M	P	S	T	R	N	M	P	S	T	R
TA 56	1-M16 x 1.5	Ø80	Ø100	Ø120	Ø7	3	0	Ø50	Ø65	Ø80	M5	2.5	0												
TA 63	1-M16 x 1.5	Ø95	Ø115	Ø140	Ø10	3	0	Ø60	Ø75	Ø90	M5	2.5	0												
TA 71	1-M20 x 1.5	Ø110	Ø130	Ø160	Ø10	3.5	0	Ø70	Ø85	Ø105	M6	2.5	0	Ø95	Ø115	Ø140	3	Ø10	0	Ø95	Ø115	Ø140	3	M8	0
TA 80	1-M20 x 1.5	Ø130	Ø165	Ø200	Ø12	3.5	0	Ø80	Ø100	Ø120	M6	3	0	Ø110	Ø130	Ø160	3.5	Ø10	0	Ø110	Ø130	Ø160	3.5	M8	0
TA 90S/L	1-M20 x 1.5	Ø130	Ø165	Ø200	Ø12	3.5	0	Ø95	Ø115	Ø140	M8	3	0	Ø110	Ø130	Ø160	3.5	Ø10	0	Ø110	Ø130	Ø160	3.5	M8	0
TA 100	2-M20 x 1.5	Ø180	Ø215	Ø250	Ø15	4	0	Ø110	Ø130	Ø160	M8	3.5	0	Ø130	Ø165	Ø200	3.5	Ø12	0	Ø130	Ø165	Ø200	3.5	M10	0
TA 112	2-M25 x 1.5	Ø180	Ø215	Ø250	Ø15	4	0	Ø110	Ø130	Ø160	M8	3.5	0	Ø130	Ø165	Ø200	3.5	Ø12	0	Ø130	Ø165	Ø200	3.5	M10	0
TA 132S/M	2-M25 x 1.5	Ø230	Ø265	Ø300	Ø15	4	0	Ø130	Ø165	Ø200	M10	3.5	0	Ø180	Ø215	Ø250	4	Ø15	0	Ø180	Ø215	Ø250	4	M12	0
TA 160M/L	2-M32 x 1.5	Ø250	Ø300	Ø350	Ø19	5	0	Ø180	Ø215	Ø250	M12	4	0												

Datos eléctricos en páginas de 3 a 8

SERIE TC

MEDIDAS EXTERIORES Y FORMAS CONSTRUCTIVAS

Tipo	B3				Eje							General							
	H	A	B	C	D	E	F	G	K	AA	AD	AH	AC	L	TBS	TBW	TBH		
160M/L	160	254	210/254*	108	Ø42	110	12	37	15	316	404	244	Ø313	605/650*	91	162	187		
180M/L	180	279	241/279*	121	Ø48	110	14	42.5	15	354	445	265	Ø360	687/725*	160/180	162	187		
200L	200	318	305	133	Ø55	110	16	49	19	393	500	300	Ø399	768.5	192	186	233		
225S	4,6,8	225	356	286	149	Ø60	140	18	53	19	440	558	333	Ø459	810	199	186	233	
225M	2	225	356	311	149	Ø55	110	16	49	19	440	558	333	Ø459	805	211.5	186	233	
	4,6,8	225	356	311	149	Ø60	140	18	53	19	440	558	333	Ø459	835	211.5	186	233	
250M	2	250	406	349	168	Ø60	140	18	53	24	484	616	366	Ø506	915	233	218	260	
	4,6,8	250	406	349	168	Ø65	140	18	58	24	484	616	366	Ø506	915	233	218	260	
280S/M	2	280	457	368/419*	190	Ø65	140	18	58	24	560	675	395	Ø559	984/1035*	265/277*	218/245*	260/280*	
	4,6,8	280	457	368/419*	190	Ø75	140	20	67.5	24	560	675	395	Ø559	984/1035*	265/277*	218/245*	260/280*	
315S	2	315	508	406	216	Ø65	140	18	58	Ø28	628	825	510	Ø680	1205	200	290	350	
	4,6,8	315	508	406	216	Ø80	170	22	71	Ø28	628	825	510	Ø680	1235	200	290	350	
315M/L	2	315	508	457/508*	216	Ø65	140	18	58	Ø28	628	825	510	Ø680	1355	200	290	350	
	4,6,8	315	508	457/508*	216	Ø80	170	22	71	Ø28	628	825	510	Ø680	1385	200	290	350	
355M/L	2	355	610	560/630*	254	Ø75	140	20	67.5	Ø28	740	1010	655	Ø820	1495	140	330	380	
	4,6,8	355	610	560/630*	254	Ø95	170	25	86	Ø28	740	1010	655	Ø820	1525	140	330	380	
4,6,8	355	610	560/630*	254	Ø100	210	28	90	Ø28	740	1010	655	Ø820	1565	140	330	380		

Tipo	Rodamientos		Prensaestopas	B5						B14					
	DE	NDE		N	M	P	S	T	R	N	M	P	S	T	R
160M/L		6309	2-M32x1.5	Ø250	Ø300	Ø350	4xØ19	5	0	180	215	250	M12	5	0
180M/L		6311	2-M32x1.5	Ø250	Ø300	Ø350	4xØ19	5	0						
200L		6312	2-M40x1.5	Ø300	Ø350	Ø400	4xØ19	5	0						
225S/M		6313	2-M50x1.5	Ø350	Ø400	Ø450	8xØ19	5	0						
250M		6314	2-M50x1.5	Ø450	Ø500	Ø550	8xØ19	5	0						
280S/M		6316	2-M50x1.5	Ø450	Ø500	Ø550	8xØ19	5	0						
315S/M/L	2	6317	2-M63x1.5	Ø550	Ø600	Ø660	8xØ24	6	0						
	4,6,8	NU319													
355M/L	2	6319	2-M63x1.5	Ø680	Ø740	Ø800	8xØ24	6	0						
	4,6,8	NU322													

*Motores de carcasa reducida

Datos eléctricos en páginas de 11 a 14

SERIE MY

MOTORES MONOFÁSICOS DE CARCASA DE ALUMINIO DE ARRANQUE NORMAL

Par normal

Gama monofásica de aluminio con condensador de marcha. La serie MY está diseñada para conseguir las máximas prestaciones. Los motores están fabricados con materiales de calidad y conforme a la normativa IEC. Flexibilidad de montaje, fiabilidad, bajo nivel de ruido y bajas vibraciones son las principales características de la serie MY. El coeficiente de par de arranque (T_{st}/T_n) tiene un rango de valores entre 0.3 y 0.7. Estos motores son adecuados para aplicaciones donde no se requiere un elevado par de arranque.

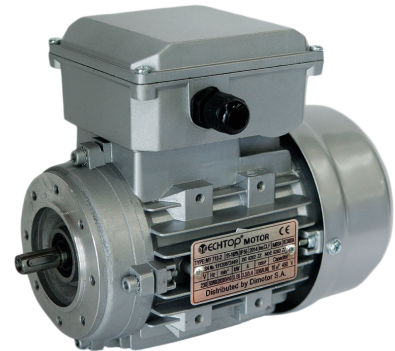

RAL 9006

MEDIDAS EXTERIORES Y FORMAS CONSTRUCTIVAS

Tipo	B3														Eje y chaveta		
	H	A	B	C	D	E	F	G	K	AA	AD	HD	AC	L	SS	XX	ZZ
MY 56	56*	90	71	36	Ø9	20	3	7.2	5.8x8.8	110	144	88	Ø110	196	M4	9	12
MY 63	63	100	80	40	Ø11	23	4	8.5	7x10	120	181	118	Ø121	220	M4	10	14
MY 71	71	112	90	45	Ø14	30	5	11	7x10	132	196	125	Ø139	241/255	M5	12	17
MY 80	80	125	100	50	Ø19	40	6	15.5	10x13	160	226	146	Ø156	290	M6	16	21
MY 90S	90	140	100	56	Ø24	50	8	20	10x13	175	243	153	Ø175	312	M8	19	25
MY 90L	90	140	125	56	Ø24	50	8	20	10x13	175	243	153	Ø175	337/367	M8	19	25
MY 100L	100	160	140	63	Ø28	60	8	24	12x15	198	265	165	Ø196	368/386	M10	22	30

Tipo	KK	B5						B14						B5R						B14B						
		N	M	P	S	T	R	N	M	P	S	T	R	N	M	P	S	T	R	N	M	P	S	T	R	
MY 56	1-M16x1.5	Ø80	Ø100	Ø120	Ø7	3	0	Ø50	Ø65	Ø80	M5	2.5	0													
MY 63	1-M20x1.5	Ø95	Ø115	Ø140	Ø10	3	0	Ø60	Ø75	Ø90	M5	2.5	0							Ø80	Ø100	Ø120	3	M6	0	
MY 71	1-M20x1.5	Ø110	Ø130	Ø160	Ø10	3.5	0	Ø70	Ø85	Ø105	M6	2.5	0	Ø95	Ø115	Ø140	3	Ø10	0	Ø95	Ø115	Ø140	3	M8	0	
MY 80	1-M20x1.5	Ø130	Ø165	Ø200	Ø12	3.5	0	Ø80	Ø100	Ø120	M6	3	0	Ø110	Ø130	Ø160	3.5	Ø10	0	Ø110	Ø130	Ø160	3.5	M8	0	
MY 90	1-M20x1.5	Ø130	Ø165	Ø200	Ø12	3.5	0	Ø95	Ø115	Ø140	M8	3	0	Ø110	Ø130	Ø160	3.5	Ø10	0	Ø110	Ø130	Ø160	3.5	M8	0	
MY 100	1-M20x1.5	Ø180	Ø215	Ø250	Ø15	4	0	Ø110	Ø130	Ø160	M8	3.5	0	Ø130	Ø165	Ø200	3.5	Ø12	0	Ø130	Ø165	Ø200	3.5	M10	0	

*Caja de bornes de plástico

IMB3

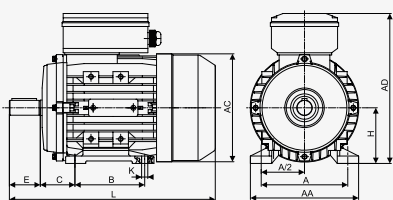

IMB5

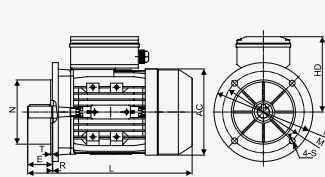

IMB14

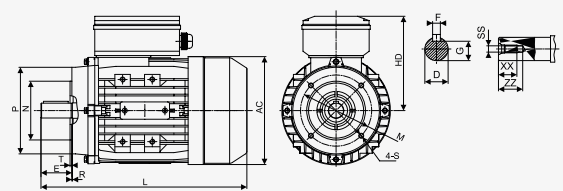

2 POLOS - 3000 RPM - 50 HZ

Tipo	Potencia (kW)	Corriente (A)	Velocidad (r/min)	Eficiencia (%)	Factor de potencia (cos Φ)	Tst/Tn	Tmax/Tn	Corriente de arranque (A)	Condensador de marcha (μf/V)	dB(A)	Peso (Kg)	Inercia (kg·m ²)
MY561-2	0.09	0.81	2750	51	0.95	0.7	1.7	2	5μf/450V	67	3	0.000093
MY562-2	0.12	0.89	2800	61	0.96	0.7	1.8	3.1	6μf/450V	67	3.2	0.000120
MY631-2	0.18	1.31	2770	62	0.96	0.55	1.8	4.5	8μf/450V	70	3.8	0.000141
MY632-2	0.25	1.65	2780	68	0.97	0.55	1.8	6	10μf/450V	70	4.5	0.000168
MY633-2	0.37	2.51	2780	67.5	0.95	0.46	1.65	8	12μf/450V	75	5	0.000216
MY634-2	0.55	3.52	2740	70	0.97	0.46	1.55	12	16μf/450V	75	5.5	0.000249
MY711-2	0.37	2.54	2780	68	0.93	0.5	1.64	9.5	12μf/450V	75	5.5	0.000330
MY712-2	0.55	3.45	2800	73	0.95	0.5	1.8	14.5	16μf/450V	75	6.7	0.000356
MY713-2	0.75	4.45	2840	75.5	0.97	0.48	1.8	20	25μf/450V	75	7	0.000436
MY801-2	0.75	4.51	2810	73	0.99	0.45	1.75	19	25μf/450V	75	8.9	0.000789
MY802-2	1.1	6.30	2810	77.5	0.98	0.45	1.8	30	35μf/450V	78	11	0.001174
MY803-2	1.5	8.48	2820	78.5	0.98	0.34	1.68	40	40μf/450V	80	12.7	0.001430
MY90S-2	1.5	8.45	2820	78	0.99	0.33	1.72	35	45μf/450V	80	12.2	0.001512
MY90L-2	2.2	12.08	2850	80	0.99	0.29	1.8	61	60μf/450V	80	15.5	0.001983
MY100L-2	3	16.7	2860	79	0.99	0.35	1.8	73	80μf/450V	83	23.1	0.004803

4 POLOS - 1500 RPM - 50 HZ

Tipo	Potencia (kW)	Corriente (A)	Velocidad (r/min)	Eficiencia (%)	Factor de potencia (cos Φ)	Tst/Tn	Tmax/Tn	Corriente de arranque (A)	Condensador de marcha (μf/V)	dB(A)	Peso (Kg)	Inercia (kg·m ²)
MY561-4	0.06	0.55	1410	49	0.97	0.7	1.8	1.5	4μf/450V	63	2.9	0.000215
MY562-4	0.09	0.78	1390	51	0.99	0.7	1.65	8	6μf/450V	63	3.4	0.000240
MY631-4	0.12	0.97	1400	55	0.98	0.7	1.75	2.5	8μf/450V	65	3.4	0.000298
MY632-4	0.18	1.35	1380	59	0.98	0.6	1.65	3.5	10μf/450V	65	4.4	0.000373
MY633-4	0.25	1.77	1380	62.5	0.98	0.55	1.6	5	12μf/450V	65	5	0.000448
MY710-4	0.18	1.33	1420	60.5	0.97	0.48	1.65	4	10μf/450V	65	5.2	0.000538
MY711-4	0.25	1.70	1410	64.5	0.99	0.5	1.6	5	12μf/450V	65	5.8	0.000641
MY712-4	0.37	2.43	1410	67.5	0.98	0.44	1.65	7.5	16μf/450V	68	6.9	0.000846
MY713-4	0.55	3.45	1385	70	0.99	0.45	1.47	10.5	20μf/450V	70	8.3	0.001052
MY800-4	0.37	2.38	1420	69	0.98	0.45	1.8	9	16μf/450V	68	8	0.001285
MY801-4	0.55	3.34	1420	73	0.98	0.45	1.78	13	20μf/450V	70	9.5	0.001618
MY802-4	0.75	4.42	1420	74.5	0.99	0.44	1.71	16.5	30μf/450V	70	10.5	0.002061
MY90S-4	1.1	6.30	1420	77.5	0.98	0.35	1.75	24	40μf/450V	73	13.1	0.002500
MY90L-4	1.5	8.55	1420	79.5	0.96	0.33	1.8	36	45μf/450V	75	16.5	0.003240
MY100L1-4	2.2	13.0	1450	79	0.93	0.31	1.8	65	70μf/450V	78	23.4	0.008045
MY100L2-4	3	16.8	1450	81	0.96	0.31	1.8	91	90μf/450V	78	28.7	0.010853

6 POLOS - 1000 RPM - 50 HZ

Tipo	Potencia (kW)	Corriente (A)	Velocidad (r/min)	Eficiencia (%)	Factor de potencia (cos Φ)	Tst/Tn	Tmax/Tn	Corriente de arranque (A)	Condensador de marcha (μf/V)	dB(A)	Peso (Kg)	Inercia (kg·m ²)
MY631-6	0.09	0.9	900	44.5	0.97	0.38	1.53	2	8μf/450V	63	4.4	0.000550
MY632-6	0.12	1.1	875	47.5	0.98	0.25	1.23	2	11μf/450V	63	5.5	0.000649
MY711-6	0.18	1.5	920	55.5	0.97	0.5	1.5	3.5	11μf/450V	68	6.2	0.000585
MY712-6	0.25	2.0	930	56	0.98	0.45	1.5	5	16μf/450V	68	7.3	0.001151
MY801-6	0.37	2.5	960	66	0.96	0.35	1.6	8.5	20μf/450V	68	9	0.002232
MY802-6	0.55	3.5	955	70.5	0.97	0.35	1.6	12	25μf/450V	70	11.6	0.002903
MY90S-6	0.75	5.0	905	67	0.98	0.35	1.6	13	35μf/450V	70	13.5	0.003523
MY90L-6	1.1	6.6	940	74	0.98	0.35	1.5	25	50μf/450V	70	16.2	0.004957

SERIE MY2

MOTORES MONOFÁSICOS DE CARCASA DE ALUMINIO DE ARRANQUE NORMAL, EFICIENCIA IE2

Par normal

Gama monofásica de aluminio con condensador de marcha. La serie MY2 está diseñada para conseguir las máximas prestaciones y nivel de eficiencia IE2. Los motores están fabricados con materiales de calidad y conforme a la normativa IEC. Flexibilidad de montaje, fiabilidad, bajo nivel de ruido y bajas vibraciones son las principales características de la serie MY2. Estos motores son adecuados para aplicaciones donde no se requiere un elevado par de arranque.



RAL 9006

MEDIDAS EXTERIORES Y FORMAS CONSTRUCTIVAS

Tipo	B3														Eje y chaveta		
	H	A	B	C	D	E	F	G	K	AA	AD	HD	AC	L	SS	XX	ZZ
MY2 56	56*	90	71	36	Ø9	20	3	7.2	6 x 9	112	145	89	Ø110	195	M4	10	14
MY2 63	63	100	80	40	Ø11	23	4	8.5	7 x 10	124	181	118	Ø122	217	M4	10	14
MY2 71	71	112	90	45	Ø14	30	5	11	7 x 10	140	197	126	Ø138	245	M5	12	17
MY2 80	80	125	100	50	Ø19	40	6	15.5	10 x 15	160	227	147	Ø157	280/304	M6	16	21
MY2 90S	90	140	100	56	Ø24	50	8	20	10 x 15	176	248	158	Ø177	315/340	M8	19	25
MY2 90L	90	140	125	56	Ø24	50	8	20	10 x 15	176	248	158	Ø177	340/365	M8	19	25
MY2 100L	100	160	140	63	Ø28	60	8	24	12 x 16	200	274	174	Ø199	376/411	M10	22	30

Tipo	KK	B5						B14						B5R						B14B					
		N	M	P	S	T	R	N	M	P	S	T	R	N	M	P	T	S	R	N	M	P	T	S	R
MY2 56	1-M16*1.5	Ø80	Ø100	Ø120	Ø7	3	0	Ø50	Ø65	Ø80	M5	2.5	0							Ø80	Ø100	Ø120	3	M6	O
MY2 63	1-M20*1.5	Ø95	Ø115	Ø140	Ø10	3	0	Ø60	Ø75	Ø90	M5	2.5	0							Ø95	Ø115	Ø140	3	M8	O
MY2 71	1-M20*1.5	Ø110	Ø130	Ø160	Ø10	3.5	0	Ø70	Ø85	Ø105	M6	2.5	0	Ø95	Ø115	Ø140	3	Ø10	0	Ø110	Ø130	Ø160	3.5	M8	O
MY2 80	1-M20*1.5	Ø130	Ø165	Ø200	Ø12	3.5	0	Ø80	Ø100	Ø120	M6	3	0	Ø110	Ø130	Ø160	3.5	Ø10	0	Ø110	Ø130	Ø160	3.5	M8	O
MY2 90	1-M20*1.5	Ø130	Ø165	Ø200	Ø12	3.5	0	Ø95	Ø115	Ø140	M8	3	0	Ø110	Ø130	Ø160	3.5	Ø10	0	Ø130	Ø165	Ø200	3.5	M10	O
MY2 100	1-M20*1.5	Ø180	Ø215	Ø250	Ø15	4	0	Ø110	Ø130	Ø160	M8	3.5	0	Ø130	Ø165	Ø200	3.5	Ø12	0	Ø130	Ø165	Ø200	3.5	M10	O

*Caja de bornes de plástico

IMB3

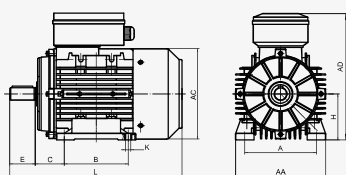

IMB5

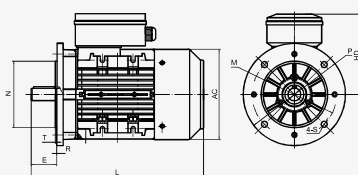

IMB14

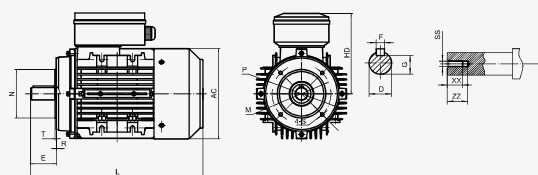

2 POLOS - 3000 RPM - 50 HZ

Tipo	Potencia (KW)	Corriente 220V (A)	Corriente 230V (A)	Corriente 240V (A)	Velocidad (rpm)	Eficiencia			Factor de potencia (cos Φ)	Tst/Tn	Tmax/Tn	Is/In	Condensador de marcha (µf/V)	dB(A)	Peso (Kg)	Inercia (kg·m²)	Código LRC
						100%	75%	50%									
MY2562-2	0.12	0.93	0.89	0.85	2800	61	53.5	42	0.96	0.7	1.8	3.4	6µf/450V	67	3.05	0.00012	D
MY2631-2	0.18	1.41	1.35	1.29	2790	60.4	54.6	44	0.96	0.5	1.75	2.9	8µf/450V	70	3.85	0.00016	C
MY2632-2	0.25	1.81	1.73	1.66	2790	64.8	61.2	51.2	0.97	0.5	1.71	3.4	10µf/450V	70	4.35	0.00020	C
MY2711-2	0.37	2.49	2.39	2.29	2790	69.5	66.3	58.0	0.97	0.5	1.8	3.9	14µf/450V	75	6.15	0.00040	D
MY2712-2	0.55	3.48	3.33	3.19	2815	74.1	71.1	66.1	0.97	0.55	1.8	4.5	20µf/450V	75	7.55	0.00053	E
MY2713-2	0.75	4.49	4.3	4.12	2840	77.4	73.8	65.7	0.98	0.52	1.8	4.7	25µf/450V	75	8.69	0.00063	E
MY2801-2	0.75	4.45	4.26	4.08	2850	77.4	75.6	68.7	0.99	0.4	1.8	4.9	25µf/450V	75	9.91	0.00092	E
MY2802-2	1.1	6.34	6.07	5.82	2830	79.6	78.6	72.3	0.99	0.38	1.8	4.9	35µf/450V	78	11.31	0.00111	E
MY290S-2	1.5	8.47	8.1	7.77	2875	81.3	79.4	73.1	0.99	0.35	1.8	5.4	40µf/450V	80	14.61	0.00170	F
MY290L-2	2.2	12.1	11.6	11.1	2880	83.2	82.9	77.7	0.99	0.33	1.8	6.1	60µf/450V	80	19.11	0.00198	F
MY2100L-2	3	16.3	15.6	14.9	2910	84.6	83.8	79.2	0.99	0.35	2	6.8	80µf/450V	83	27.7	0.00587	G

4 POLOS - 1500 RPM - 50 HZ

Tipo	Potencia (KW)	Corriente 220V (A)	Corriente 230V (A)	Corriente 240V (A)	Velocidad (rpm)	Eficiencia			Factor de potencia (cos Φ)	Tst/Tn	Tmax/Tn	Is/In	Condensador de marcha (µf/V)	dB(A)	Peso (Kg)	Inercia (kg·m²)	Código LRC
						100%	75%	50%									
MY2563-4	0.12	0.93	0.89	0.85	1400	59.1	51.1	39.5	0.99	0.6	1.63	2.5	6µf/450V	65	4.58	0.00032	B
MY2631-4	0.12	0.93	0.89	0.85	1425	59.1	51.1	39.2	0.99	0.6	1.75	2.6	8µf/450V	65	4.35	0.00036	B
MY2632-4	0.18	1.28	1.22	1.17	1420	64.7	57.5	45.3	0.99	0.51	1.68	2.9	10µf/450V	65	5.15	0.00045	B
MY2632-6	0.12	1.09	1.04	1.00	915	50.6	43.9	33.2	0.99	0.6	1.42	1.8	8µf/450V	63	5.35	0.00052	A
MY2711-4	0.25	1.68	1.6	1.54	1435	68.5	61.9	50.0	0.99	0.5	1.7	3.0	14µf/450V	65	6.25	0.00078	B
MY2712-4	0.37	2.34	2.24	2.14	1430	72.7	66.9	55.1	0.99	0.44	1.7	3.3	20µf/450V	68	7.45	0.00103	C
MY2801-4	0.55	3.28	3.13	3.00	1420	77.1	73.7	64.8	0.99	0.33	1.7	3.8	25µf/450V	70	9.91	0.00156	C
MY2802-4	0.75	4.33	4.14	3.97	1420	79.6	77.2	69.3	0.99	0.4	1.8	4.1	30µf/450V	70	12.01	0.00208	C
MY290S-4	1.1	6.2	5.93	5.69	1435	81.4	78.8	71.0	0.99	0.37	1.75	3.8	40µf/450V	73	15.01	0.00289	C
MY290L-4	1.5	8.32	7.96	7.62	1430	82.8	81.1	74.6	0.99	0.3	1.8	4.6	40µf/450V	75	18.81	0.00389	D
MY2100L1-4	2.2	12.0	11.5	11.0	1450	84.3	82.5	75.8	0.99	0.3	1.8	4.2	70µf/450V	78	25.4	0.00941	C

6 POLOS - 1000 RPM - 50 HZ

Tipo	Potencia (KW)	Corriente 220V (A)	Corriente 230V (A)	Corriente 240V (A)	Velocidad (rpm)	Eficiencia			Factor de potencia (cos Φ)	Tst/Tn	Tmax/Tn	Is/In	Condensador de marcha (µf/V)	dB(A)	Peso (Kg)	Inercia (kg·m²)	Código LRC
						100%	75%	50%									
0	0.18	1.46	1.4	1.34	940	56.6	50.6	38.7	0.99	0.5	1.62	2.6	11µf/450V	68	6.15	0.00102	B
MY2712-6	0.25	1.86	1.78	1.71	940	61.6	54.1	41.9	0.99	0.5	1.66	2.8	16µf/450V	68	7.05	0.00125	B
MY2801-6	0.37	2.56	2.45	2.35	950	67.6	61.3	55.3	0.97	0.38	1.75	3	20µf/450V	68	9.71	0.00215	B
MY2802-6	0.55	3.49	3.34	3.2	955	73.1	67.5	56.7	0.98	0.3	1.7	3.3	25µf/450V	70	18.41	0.00304	B
MY290S-6	0.75	4.54	4.34	4.16	950	75.9	72.2	61.8	0.99	0.34	1.59	3.1	35µf/450V	70	14.3	0.00394	B
MY290L-6	1.1	6.47	6.19	5.93	955	78.1	74.7	64.9	0.99	0.3	1.57	3.4	45µf/450V	70	18.51	0.00556	B
MY2100L-6	1.5	8.63	8.26	7.91	965	79.8	76	67	0.99	0.3	1.52	3.1	60µf/450V	72	24.6	0.01073	B

SERIE ML

MOTORES MONOFÁSICOS DE CARCASA DE ALUMINIO CON ARRANQUE REFORZADO

Par fuerte

Gama monofásica de aluminio con condensador de arranque y condensador de marcha. La serie ML está diseñada para conseguir las máximas prestaciones. Los motores están fabricados con materiales de calidad y conforme a la normativa IEC. Flexibilidad de montaje, fiabilidad, bajo nivel de ruido y bajas vibraciones son las principales características de la serie ML. El coeficiente de par de arranque (T_{st}/T_n) puede llegar a alcanzar el valor 2.5. Estos motores son adecuados para aplicaciones donde se requiere un mayor par de arranque y alta sobrecarga, como compresores de aire, bombas, etc

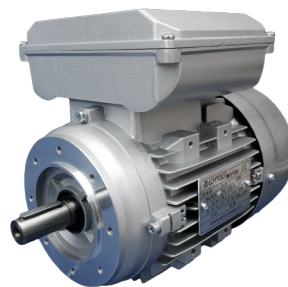

RAL 9006

MEDIDAS EXTERIORES Y FORMAS CONSTRUCTIVAS

Tipo	B3														Eje y chaveta		
	H	A	B	C	D	E	F	G	K	AA	AD	HD	AC	L	SS	XX	ZZ
ML 63	63	100	80	40	Ø11	23	4	8.5	7×10	120	179	116	Ø121	220	M4	10	14
ML 71	71	112	90	45	Ø14	30	5	11	7×10	132	194	123	Ø139	255	M5	12	17
ML 80	80	125	100	50	Ø19	40	6	15.5	10×13	160	223	143	Ø156	290	M6	16	21
ML 90S	90	140	100	56	Ø24	50	8	20	10×13	175	240	150	Ø175	337	M8	19	25
ML 90L	90	140	125	56	Ø24	50	8	20	10×13	175	240	150	Ø175	367	M8	19	25
ML 100L	100	160	140	63	Ø28	60	8	24	12×15	198	271	171	Ø196	403(421)	M10	22	30
ML 112M	112	190	140	70	Ø28	60	8	24	12×15	220	297	185	Ø221	431	M10	22	30

Tipo	KK	B5						B14						B5R				B14B								
		A	B	C	D	E	F	F	F	F	K	K	K	ZZ	ZZ	AA	AA	AA	AC	AC	AC	AC	AC	AC	AC	
ML 63	1-M20x1.5	Ø95	Ø115	Ø140	Ø10	3	0	Ø60	Ø75	Ø90	M5	2.5	0													
ML 71	1-M20x1.5	Ø110	Ø130	Ø160	Ø10	3.5	0	Ø70	Ø85	Ø105	M6	2.5	0	Ø95	Ø115	Ø140	3	Ø10	0	Ø95	Ø115	Ø140	3	M8	0	
ML 80	1-M20x1.5	Ø130	Ø165	Ø200	Ø12	3.5	0	Ø80	Ø100	Ø120	M6	3	0	Ø110	Ø130	Ø160	3.5	Ø10	0	Ø110	Ø130	Ø160	3.5	M8	0	
ML 90	1-M20x1.5	Ø130	Ø165	Ø200	Ø12	3.5	0	Ø95	Ø115	Ø140	M8	3	0	Ø110	Ø130	Ø160	3.5	Ø10	0	Ø110	Ø130	Ø160	3.5	M8	0	
ML 100	1-M20x1.5	Ø180	Ø215	Ø250	Ø15	4	0	Ø110	Ø130	Ø160	M8	3.5	0	Ø130	Ø165	Ø200	3.5	Ø12	0	Ø130	Ø165	Ø200	3.5	M10	0	
ML 112	1-M25x1.5	Ø180	Ø215	Ø250	Ø15	4	0	Ø110	Ø130	Ø160	M8	3.5	0	Ø130	Ø165	Ø200	3.5	Ø12	0	Ø130	Ø165	Ø200	3.5	M10	0	

IMB3

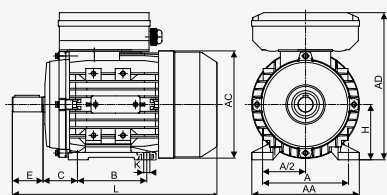

IMB5

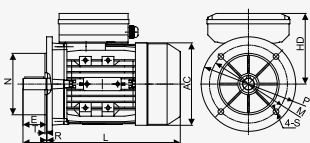

IMB14

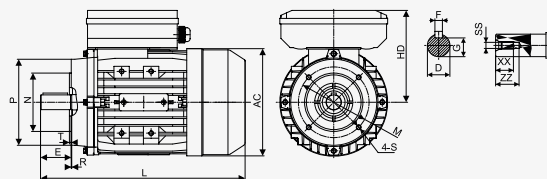

2 POLOS - 3000 RPM - 50 HZ

Tipo	Potencia (kW)	Corriente (A)	Velocidad (r/min)	Eficiencia (%)	Factor de potencia (cos Φ)	Tst/Tn	Tmax/Tn	Corriente de arranque (A)	Condensador de marcha (μf/V)	Condensador de arranque (μf/V)	dB(A)	Peso (Kg)	Inercia (kg·m ²)
ML631-2	0.18	1.36	2820	62	0.93	1.9	1.8	7	8μf/450V	30μf/250V	70	3.9	0.000141
ML632-2	0.25	1.71	2800	67.5	0.94	2.3	1.8	8	10μf/450V	30μf/250V	70	4.4	0.000168
ML711-2	0.37	2.40	2780	70.5	0.95	2.5	1.6	12	12μf/450V	40μf/250V	75	6.2	0.000330
ML712-2	0.55	3.31	2790	74.5	0.97	2.5	1.8	20	16μf/450V	50μf/250V	75	7	0.000437
ML801-2	0.75	4.25	2840	77.5	0.99	2.5	1.8	30	20μf/450V	75μf/250V	75	9	0.000781
ML802-2	1.1	6.08	2850	79.5	0.99	2.3	1.8	40	30μf/450V	120μf/250V	78	10.3	0.000938
ML90S-2	1.5	8.23	2860	80	0.99	2.5	1.8	56	40μf/450V	200μf/300V	80	13.8	0.001512
ML90M-2	1.8	9.76	2860	81	0.99	2.5	1.8	65	40μf/450V	200μf/300V	80	15.1	0.001752
ML90L-2	2.2	11.9	2850	81	0.99	2.5	1.75	15	50μf/450V	250μf/300V	80	16.8	0.001995
ML100L-2	3	17.7	2830	75	0.98	2.5	1.63	110	60μf/450V	300μf/300V	83	25	0.004803
ML112M1-2	3.7	19.9	2900	82.5	0.98	2.5	1.8	155	60μf/450V	400μf/300V	84	31	0.007170
ML112M2-2	4	21.3	2900	83.5	0.98	2.5	1.8	165	60μf/450V	400μf/300V	84	33	0.007453

4 POLOS - 1500 RPM - 50 HZ

Tipo	Potencia (kW)	Corriente (A)	Velocidad (r/min)	Eficiencia (%)	Factor de potencia (cos Φ)	Tst/Tn	Tmax/Tn	Corriente de arranque (A)	Condensador de marcha (μf/V)	Condensador de arranque (μf/V)	dB(A)	Peso (Kg)	Inercia (kg·m ²)
ML631-4	0.12	1.01	1380	54.5	0.95	2.5	1.65	6	8μf/450V	30μf/250V	65	4.1	0.000291
ML632-4	0.18	1.36	1340	60	0.96	2.3	1.43	6	10μf/450V	30μf/250V	65	4.5	0.000340
ML711-4	0.25	1.78	1415	63	0.97	2.5	1.7	10	12μf/450V	40μf/250V	65	5.9	0.000598
ML712-4	0.37	2.53	1410	65.5	0.97	2.3	1.6	15	16μf/450V	50μf/250V	68	6.9	0.000760
ML800-4	0.37	2.52	1420	66.5	0.96	2.5	1.8	15	16μf/450V	50μf/250V	68	8.5	0.001105
ML801-4	0.55	3.52	1420	71.5	0.95	2.5	1.8	20	20μf/450V	75μf/250V	70	9.6	0.001380
ML802-4	0.75	4.56	1420	73	0.98	2.5	1.75	27	25μf/450V	100μf/250V	70	10.9	0.001656
ML90S-4	1.1	6.62	1420	76	0.95	2.5	1.7	40	35μf/450V	150μf/250V	73	13.8	0.002510
ML90L-4	1.5	8.56	1420	78.5	0.97	2.5	1.75	55	40μf/450V	200μf/300V	75	16.7	0.003252
ML100L0-4	1.84	10.3	1440	79.5	0.98	2.3	1.62	60	50μf/450V	200μf/300V	77	21	0.006804
ML100L1-4	2.2	12.1	1440	80.5	0.98	2.5	1.65	80	50μf/450V	250μf/300V	78	22.8	0.008045
ML100L2-4	3	16.4	1445	83	0.96	2.4	1.75	110	60μf/450V	300μf/300V	78	28.7	0.010543
ML112M1-4	3.7	19.7	1430	83.5	0.98	2.4	1.75	130	60μf/450V	400μf/300V	79	31	0.013608
ML112M2-4	4	21.3	1435	83.5	0.98	2.5	1.75	140	60μf/450V	400μf/300V	79	32.8	0.014485

6 POLOS - 1000 RPM - 50 HZ

Tipo	Potencia (kW)	Corriente (A)	Velocidad (r/min)	Eficiencia (%)	Factor de potencia (cos Φ)	Tst/Tn	Tmax/Tn	Corriente de arranque (A)	Condensador de marcha (μf/V)	Condensador de arranque (μf/V)	dB(A)	Peso (Kg)	Inercia (kg·m ²)
ML711-6	0.18	1.3	930	60	0.97	2.3	1.72	7	10μf/450V	40μf/250V	68	6.7	0.000965
ML801-6	0.37	2.5	935	67	0.97	2.2	1.55	13	16μf/450V	50μf/250V	68	10.1	0.001829
ML802-6	0.55	3.5	935	71	0.97	2.2	1.45	20	20μf/450V	75μf/250V	70	10.8	0.002366
ML90S-6	0.75	4.7	945	71	0.97	2.1	1.45	35	30μf/450V	150μf/250V	70	14.2	0.003534
ML90L-6	1.1	6.7	945	74	0.96	2.5	1.45	45	45μf/450V	200μf/300V	70	17.3	0.004792
ML100L-6	1.5	8.73	960	77	0.97	2.3	1.55	60	45μf/450V	200μf/300V	72	23.8	0.010784
ML112M-6	2.2	12.0	965	82	0.97	2.5	1.7	100	60μf/450V	400μf/300V	75	31.2	0.019523

SERIE ML2

MOTORES MONOFÁSICOS DE CARCASA DE ALUMINIO CON ARRANQUE REFORZADO, EFICIENCIA IE2

Par fuerte

Gama monofásica de aluminio con condensador de marcha. La serie ML2 está diseñada para conseguir las máximas prestaciones y nivel de eficiencia IE2. Los motores están fabricados con materiales de calidad y conforme a la normativa IEC. Flexibilidad de montaje, fiabilidad, bajo nivel de ruido y bajas vibraciones son las principales características de la serie ML2. Estos motores son adecuados para aplicaciones donde se requiere un mayor par de arranque y alta sobrecarga, como compresores de aire, bombas, etc.

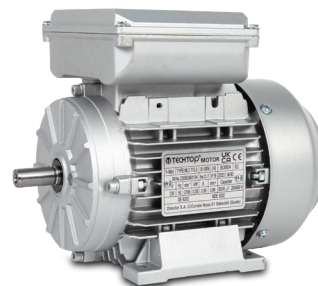

RAL 9006

MEDIDAS EXTERIORES Y FORMAS CONSTRUCTIVAS

Tipo	B3														Eje y chaveta		
	H	A	B	C	D	E	F	G	K	AA	AD	HD	AC	L	SS	XX	ZZ
ML2 63	63	100	80	40	Ø11	23	4	8.5	7 x 10	124	179	116	Ø122	217	M4	10	14
ML2 71	71	112	90	45	Ø14	30	5	11	7 x 10	140	195	124	Ø138	245	M5	12	17
ML2 80	80	125	100	50	Ø19	40	6	15.5	10 x 15	160	223	143	Ø157	280/304	M6	16	21
ML2 90S	90	140	100	56	Ø24	50	8	20	10 x 15	176	244	154	Ø177	315/340	M8	19	25
ML2 90L	90	140	125	56	Ø24	50	8	20	10 x 15	176	244	154	Ø177	340/365	M8	19	25
ML2 100L	100	160	140	63	Ø28	60	8	24	12 x 16	200	276	176	Ø199	376/411	M10	22	30
ML2 112M	112	190	140	70	Ø28	60	8	24	12 x 16	224	299	187	Ø220	398	M10	22	30

Tipo	KK	B5						B14						B5R						B14B					
		N	M	P	S	T	R	N	M	P	S	T	R	N	M	P	T	S	R	N	M	P	T	S	
ML2 63	1-M20*1.5	Ø95	Ø115	Ø140	Ø10	3	0	Ø60	Ø75	Ø90	M5	2.5	0							Ø80	Ø100	Ø120	3	M6	0
ML2 71	1-M20*1.5	Ø110	Ø130	Ø160	Ø10	3.5	0	Ø70	Ø85	Ø105	M6	2.5	0	Ø95	Ø115	Ø140	3	Ø10	0	Ø95	Ø115	Ø140	3	M8	0
ML2 80	1-M20*1.5	Ø130	Ø165	Ø200	Ø12	3.5	0	Ø80	Ø100	Ø120	M6	3	0	Ø110	Ø130	Ø160	3.5	Ø10	0	Ø110	Ø130	Ø160	3.5	M8	0
ML2 90	1-M20*1.5	Ø130	Ø165	Ø200	Ø12	3.5	0	Ø95	Ø115	Ø140	M8	3	0	Ø110	Ø130	Ø160	3.5	Ø10	0	Ø110	Ø130	Ø160	3.5	M8	0
ML2 100	1-M20*1.5	Ø180	Ø215	Ø250	Ø15	4	0	Ø110	Ø130	Ø160	M8	3.5	0	Ø130	Ø165	Ø200	3.5	Ø12	0	Ø130	Ø165	Ø200	3.5	M10	0
ML2 112	1-M25*1.5	Ø180	Ø215	Ø250	Ø15	4	0	Ø110	Ø130	Ø160	M8	3.5	0	Ø130	Ø165	Ø200	3.5	Ø12	0	Ø130	Ø165	Ø200	3.5	M10	0

*Caja de bornes de plástico

IMB3

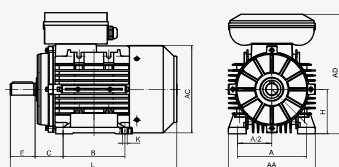

IMB5

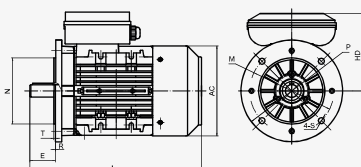

IMB14

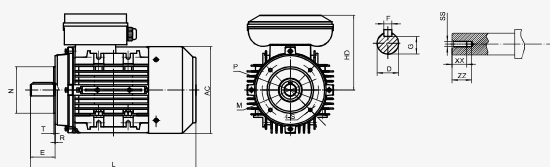

2 POLOS - 3000 RPM - 50 HZ

Tipo	Potencia (KW)	Corriente 220V (A)	Corriente 230V (A)	Corriente 240V (A)	Velocidad (rpm)	Eficiencia			Factor de potencia (cos Φ)	Tst/Tn	Tmax/Tn	Is/In	Condensador de arranque (μF/V)	Condensador de marcha (μF/V)	dB(A)	Peso (Kg)	Inercia (kg·m²)	Código LRC
						100%	75%	50%										
ML2 631-2	0.18	1.41	1.35	1.29	2790	60.4	54.5	43.4	0.96	2.4	1.75	4.9	30 μF/250V	8μf/450V	70	4.11	0.00016	G
ML2 632-2	0.25	1.81	1.73	1.66	2790	64.8	60.5	51.0	0.97	2.1	1.8	4.9	30 μF/250V	10 μF/450V	70	4.61	0.00020	F
ML2 711-2	0.37	2.52	2.41	2.31	2810	69.5	66.4	58.4	0.96	2	1.8	4.9	40 μF/250V	12μf/450V	75	6.41	0.00040	F
ML2 712-2	0.55	3.51	3.36	3.22	2795	74.1	72.0	65.1	0.96	2.3	1.8	5.1	50 μF/250V	16 μF/450V	75	7.41	0.00050	F
ML2 801-2	0.75	4.49	4.30	4.12	2830	77.4	76.7	71.1	0.98	2.49	1.78	6.1	100μf/250V	20μf/450V	75	9.66	0.00086	G
ML2 802-2	1.1	6.34	6.07	5.82	2840	79.6	79.4	74.5	0.99	2.4	1.8	6.5	150μf/250V	30μf/450V	78	11.46	0.00111	G
ML2 802-2B	1.3	7.57	7.24	6.94	2845	80.5	80.3	75.4	0.97	2.1	1.8	6.5	150 μF/250V	35μf/450V	79	12.8	0.00124	G
ML2 803-2	1.5	8.47	8.10	7.77	2815	81.3	81.3	76.6	0.99	2.3	1.8	5.9	150 μF/250V	40μf/450V	80	14.1	0.00137	G
ML2 90S-2	1.5	8.56	8.19	7.84	2860	81.3	81.49	77.29	0.98	2.3	1.8	6.4	200μf/300V	35μf/450V	80	14.36	0.00221	G
ML2 90L-2	2.2	12.1	11.6	11.1	2880	83.2	83.6	79.51	0.99	2.5	1.8	6.7	250 μF/300V	50 μf/450V	80	18.26	0.00223	H
ML2 100L-2	3	16.3	15.6	14.9	2900	84.6	84.4	81	0.99	2.5	1.8	7	300 μF/300V	55 μF/450V	83	26.7	0.00587	H
ML2 112M1-2	3.7	19.9	19.0	18.2	2890	85.5	86.1	83.2	0.99	2.5	1.8	6.3	350 μF/300V	60 μF/450V	84	33.2	0.00850	G
ML2 112M2-2	4	21.4	20.5	19.6	2890	85.8	86.4	83.5	0.99	2.5	1.8	6.4	350 μF/300V	60 μF/450V	84	33.9	0.00882	G

4 POLOS - 1500 RPM - 50 HZ

Tipo	Potencia (KW)	Corriente 220V (A)	Corriente 230V (A)	Corriente 240V (A)	Velocidad (rpm)	Eficiencia			Factor de potencia (cos Φ)	Tst/Tn	Tmax/Tn	Is/In	Condensador de arranque (μF/V)	Condensador de marcha (μF/V)	dB(A)	Peso (Kg)	Inercia (kg·m²)	Código LRC
						100%	75%	50%										
ML2 631-4	0.12	0.93	0.89	0.85	1425	59.1	51.72	39.49	0.99	2.4	1.8	5.5	30 μF/250V	8μf/450V	65	4.61	0.00036	H
ML2 632-4	0.18	1.29	1.23	1.18	1410	64.7	57.2	45	0.98	2.5	1.6	5.2	30 μF/250V	10μf/450V	65	5.31	0.00042	G
ML2 633-4	0.25	1.68	1.60	1.54	1415	68.5	62.8	51.2	0.99	2.5	1.65	5.3	40 μF/250V	12μf/450V	65	6.44	0.00056	G
ML2 711-4	0.25	1.69	1.62	1.55	1440	68.5	61.7	49.8	0.98	2.5	1.8	5.7	40 μF/250V	12μf/450V	65	6.41	0.00078	G
ML2 712-4	0.37	2.34	2.24	2.14	1430	72.7	66.9	55.5	0.99	2.4	1.65	5.4	50 μF/250V	16μf/450V	68	7.61	0.00103	G
ML2 801-4	0.55	3.28	3.13	3.00	1415	77.1	75.41	67.59	0.99	2.4	1.65	5.3	75μf/250V	20μf/450V	70	9.76	0.00145	F
ML2 802-4	0.75	4.33	4.14	3.97	1430	79.6	78.1	71.5	0.99	2.5	1.75	5.7	100μf/250V	25μf/450V	70	11.76	0.00198	F
ML2 90S-4	1.1	6.20	5.93	5.69	1435	81.4	80.09	73.15	0.99	2.5	1.75	5.8	150 μF/250V	35μf/450V	73	14.66	0.00275	F
ML2 90L-4	1.5	8.32	7.96	7.62	1430	82.8	83.1	79.1	0.99	2.3	1.75	5.6	200μf/300V	40μf/450V	75	18.56	0.00375	F
ML2100L1-4	2.2	12.1	11.6	11.1	1460	84.3	84.33	79.46	0.98	2.3	1.8	6.1	250 μF/300V	50 μF/450V	78	24.33	0.00845	F
ML2 100L2-4	3	16.6	15.9	15.2	1460	85.5	84.96	80.64	0.96	2.3	1.8	6.5	350 μF/300V	60 μF/450V	78	30.13	0.01139	F
ML2 112M1-4	3.7	20.1	19.2	18.4	1460	86.3	87.43	84.3	0.97	1.86	1.8	6.5	400 μF/300V	60 μF/450V	79	34.23	0.01529	G
ML2 112M2-4	4	21.9	20.9	20.0	1465	86.6	86.0	82.6	0.96	2.1	1.8	6.9	400 μF/300V	60 μF/450V	79	36.73	0.01684	G

6 POLOS - 1000 RPM - 50 HZ

Tipo	Potencia (KW)	Corriente 220V (A)	Corriente 230V (A)	Corriente 240V (A)	Velocidad (rpm)	Eficiencia			Factor de potencia (cos Φ)	Tst/Tn	Tmax/Tn	Is/In	Condensador de arranque (μF/V)	Condensador de marcha (μF/V)	dB(A)	Peso (Kg)	Inercia (kg·m²)	Código LRC
						100%	75%	50%										
ML2 632-6	0.12	1.09	1.04	1.00	915	50.6	43.9	33.2	0.99	2.5	1.42	3.1	20 μF/250V	8μf/450V	63	5.4	0.00052	D
ML2 711-6	0.18	1.46	1.40	1.34	940	56.6	50.5	38.5	0.99	2.3	1.6	4	30 μF/250V	10 μF/450V	68	6.21	0.00094	E
ML2 712-6	0.25	1.88	1.80	1.73	940	61.6	55.2	43.9	0.98	2.3	1.67	4.1	40 μF/250V	14μf/450V	68	7.21	0.00125	E
ML2 801-6	0.37	2.59	2.48	2.38	950	67.6	61.1	49.5	0.96	2.4	1.5	5.2	50 μF/250V	16 μF/450V	68	9.56	0.00201	G
ML2 802-6	0.55	3.60	3.44	3.30	945	73.1	70	60.1	0.95	2.4	1.5	5.7	75 μF/250V	20μf/450V	68	11.06	0.00260	G
ML2 90S-6	0.75	4.54	4.34	4.16	950	75.9	72.2	61.8	0.99	2.4	1.65	7	150 μF/300V	30μf/450V	70	14.4	0.00394	H
ML2 90L-6	1.1	6.47	6.19	5.93	950	78.1	75.89	66.73	0.99	2.5	1.52	6.9	200 μF/300V	45 μF/450V	70	18.06	0.00536	H
ML2 100L-6	1.5	8.90	8.51	8.16	965	79.8	76.9	68.9	0.96	2.5	1.6	6.6	200 μF/300V	45 μF/450V	72	23.53	0.00966	H
ML2 112M-6	2.2	12.6	12.1	11.6	975	81.8	78.6	71	0.97	1.87	1.8	5.4	200 μF/300V	60 μF/450V	75	31.73	0.01949	H

SERIE EC / ECI

MOTORES CONMUTADOS ELECTRÓNICAMENTE

Como fabricante internacional de motores eléctricos, nos preocupamos por el medioambiente y el ahorro de energía. Uno de nuestros objetivos principales es ayudar a nuestros clientes a reducir los costes de inversión, aumentar la rentabilidad y hacer que la producción sea lo más ecológica posible.

Los motores Techtop serie EC (conmutados electrónicamente) son motores PMS (sincrónicos de imanes permanentes) diseñados en carcasas IEC y disponibles en cuatro tamaños diferentes 71, 90, 100 y 112. La potencia máxima es de 22kW y el par máximo es de 70Nm

Para estar calificados para la próxima generación que requerirá productos de mayor ahorro energético, los motores Techtop EC tienen las siguientes ventajas:

- > Eficiencia extremadamente alta, el valor promedio supera las normas IE4.
- > Alta eficiencia en un amplio rango de velocidad.
- > Diseño similar a los motores de aluminio Techtop.
- > Dimensiones de montaje según la norma IEC.
- > Varios tipos de montajes adecuados a diferentes aplicaciones.

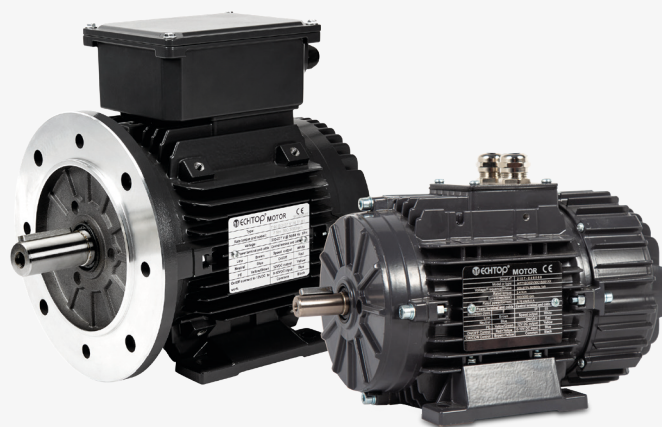

> Los motores EC contienen dos series:

- ECI: motores de imanes permanentes con accionamiento integrado.
Desde el tamaño 71 al 90
- EC: motores de imanes permanentes.
Desde el tamaño 71 al 132

> Tamaño 71 con accionamiento integrado trasero.

> Tamaño 90 con accionamiento integrado superior.

Serie ECI

Tipo	Carcasa	Par nominal (Nm)**	Potencia @1500rpm (kW)	Potencia @3000rpm (kW)	Velocidad máxima
T71ECI01X36	71	1.2	0.2	0.41	3600
T71ECI02X36		2.4	0.41	0.82	3000
T71ECI03X18		3.2	0.55	-	1800
T90ECI03X36	90	3.2	0.55	1.1	3600
T90ECI05X30		4.8	0.75	1.5	3000
T90ECI07X18		7	1.1	-	1800

** El par nominal se basa en el método de refrigeración del motor. Para el par detallado, consultar hoja de datos. Funciones de accionamiento:

- Elección CW/CCW
- Terminales Start-stop
- 0-10VDC control de velocidad
- RS485 Modbus
- Control manual de velocidad por resistencia ajustable
- Feedback de velocidad

Serie EC

Tipo	Carcasa	Par nominal (Nm)**	Potencia @1500rpm (kW)	Potencia @3000rpm (kW)	Velocidad máxima
T71EC01X36	71	1.2	0.2	0.41	3600
T71EC02X36		2.4	0.41	0.82	3600
T71EC03X36		3.2	0.55	1.1	3000
T90EC03X36	90	3.2	0.55	1.1	3600
T90EC05X36		4.8	0.75	1.5	3600
T90EC07X36		7	1.1	2.2	3600
T100EC10X36	100	9.5	1.5	3	3600
T100EC14X36		14	2.2	4	3600
T100EC19X30		19.1	3	5.5	3000
T132EC26X30	132	25.5	4	7.5	3000
T132EC35X30		35	5.5	11	3000
T132EC48X30		47.7	7.5	15	3000
T132EC59X30		58.9	9.2	18.5	3000
T132EC70X30		70	11	22	3000

** El par nominal se basa en el método de refrigeración del motor. Para el par detallado consultar la ficha técnica

Serie ECI

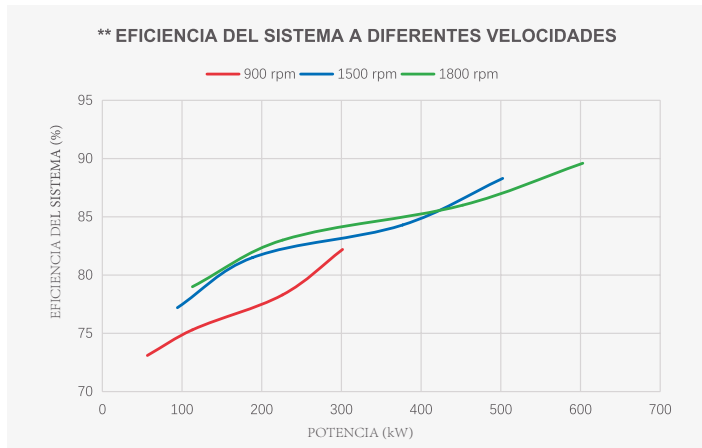

** La eficiencia del sistema incluye la eficiencia del motor y la del drive.

Serie EC

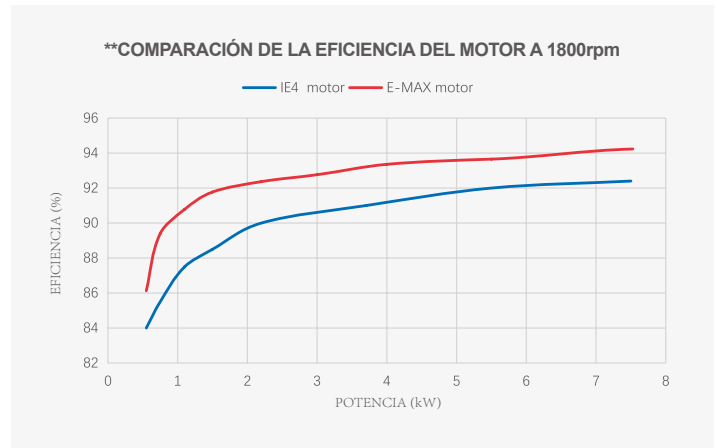

** La eficiencia es solo la del motor.

Rango de productos

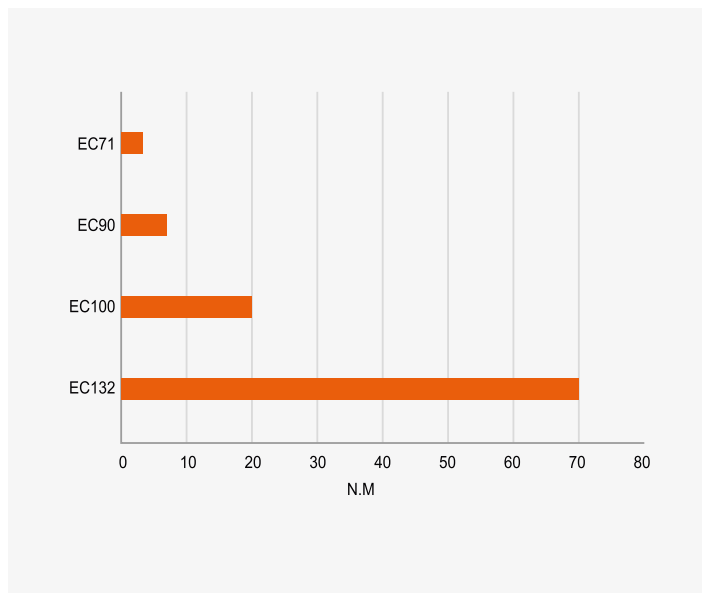

Modelo y Nomenclatura

T 90 EC 03 V 36 C2 B14 P T1
1 2 3 4 5 6 7 8 9 10

Posición	Código	Descripción
1	"T"	Product platform
2	"90"	Frame size: IEC 90#
3	"EC"	"EC: permanent magnet motor ECI: permanent magnet motor with integrated drive"
4	"03"	Rated torque
5	"V"	"Cooling method: G = General purposes, with fan and fan hood. IC411 V = Ventilation applications, without fan and fan hood."
6	"36"	Maximum speed: 3600 rpm
7	C2	"Power line connection method: T1 = Terminal box on top T2 = Terminal box on NDE C1 = No terminal box, power line from housing C2 = No terminal box, power line from NDE"
8	B14	Mounting method: B3, B4, B5, B34, B35
9	P	P = Slid rail
10	T1	"Voltage code: T1: 3 phase 360-440 V, T2: 3 phase 200-240 V S1: 1 phase 200-240 V, S2: 1 phase 115 V"

Parametrización para VSD

Parámetro	Estrella	Triángulo	Unidad de medida	Notas
VSD input voltage:	360-440	360-440	V	
Max speed:	1800	3600	rpm	
Max frequency:	150	300	Hz	
VSD output voltage:	360	360	V	
Rated current:	2.65	4.8	A	
Resistance:	1.45	0.49	Ohm	Phase
Ld:	9.5	3.1	mH	Phase
Lq:	9.5	3.1	mH	Phase
Back EMF value:	167	90	Vrms per 100 rpm	



> Consideración VFD

- Los motores PMS deben ser controlados por VSD, el motor no puede conectarse directamente a la red. El VSD puede ser de tipo comercial con control vectorial o modo de control de motor PM. El VSD necesita configurarse con los parámetros correcto del motor (ver la tabla a continuación). Los parámetros detallados se pueden encontrar en la ficha técnica.

Servicio: S1
Tipo de ventilación: IC410, IC411, Ventilador axial externo

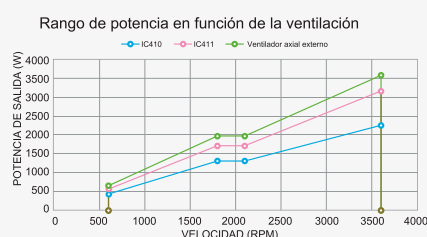

> Elección de potencia

- La potencia indicada en la gráfica es la potencia nominal cuando el motor no tiene ningún método de enfriamiento (IC410). Si el motor se refrigera con un ventilador o por la misma carga, la potencia del motor puede ser mayor (ver gráfica a la izquierda). En la gráfica detallamos el valor de potencia en diferentes condiciones de refrigeración.

DIMENSIONES GENERALES EXTERIORES



> IC 410



> IC 411

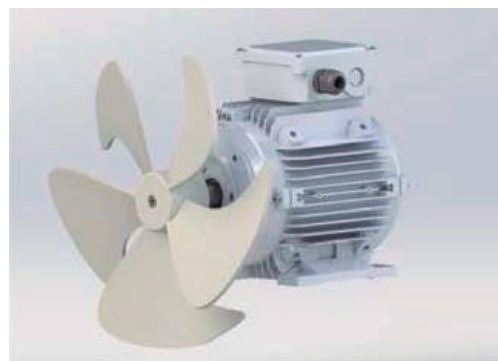

> Ventilador axial externo

T71ECI motor con accionamiento integrado (B3)

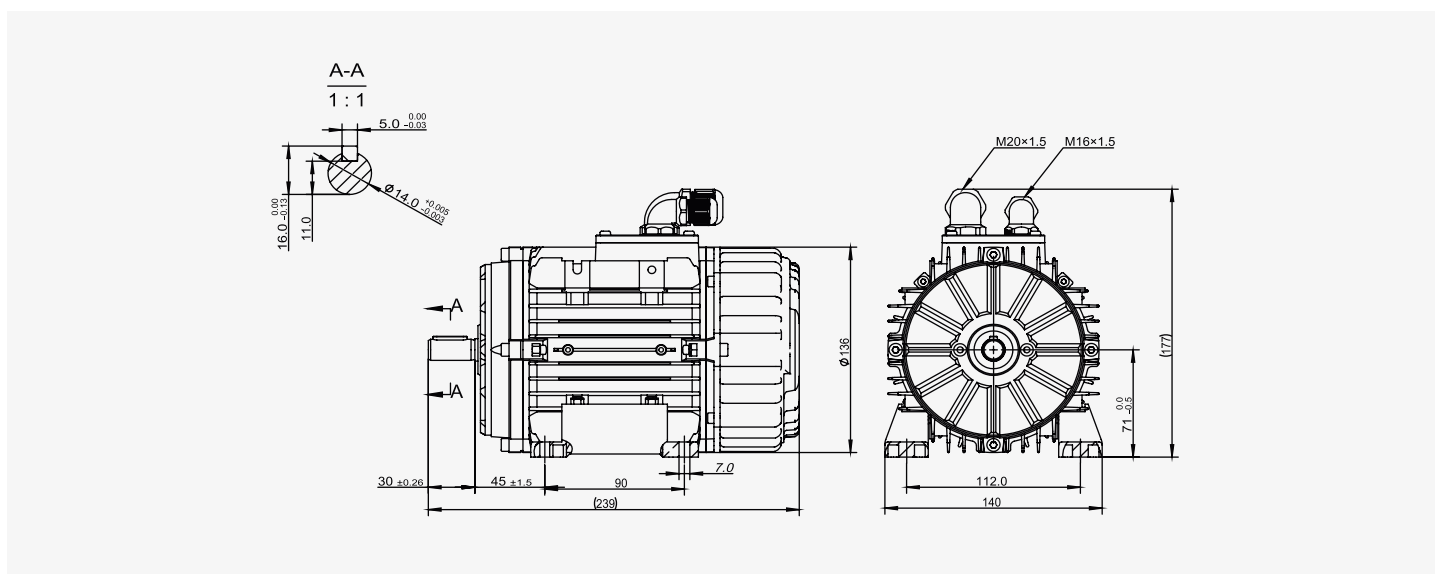

T90EC motor autoventilado (B3, IC411)

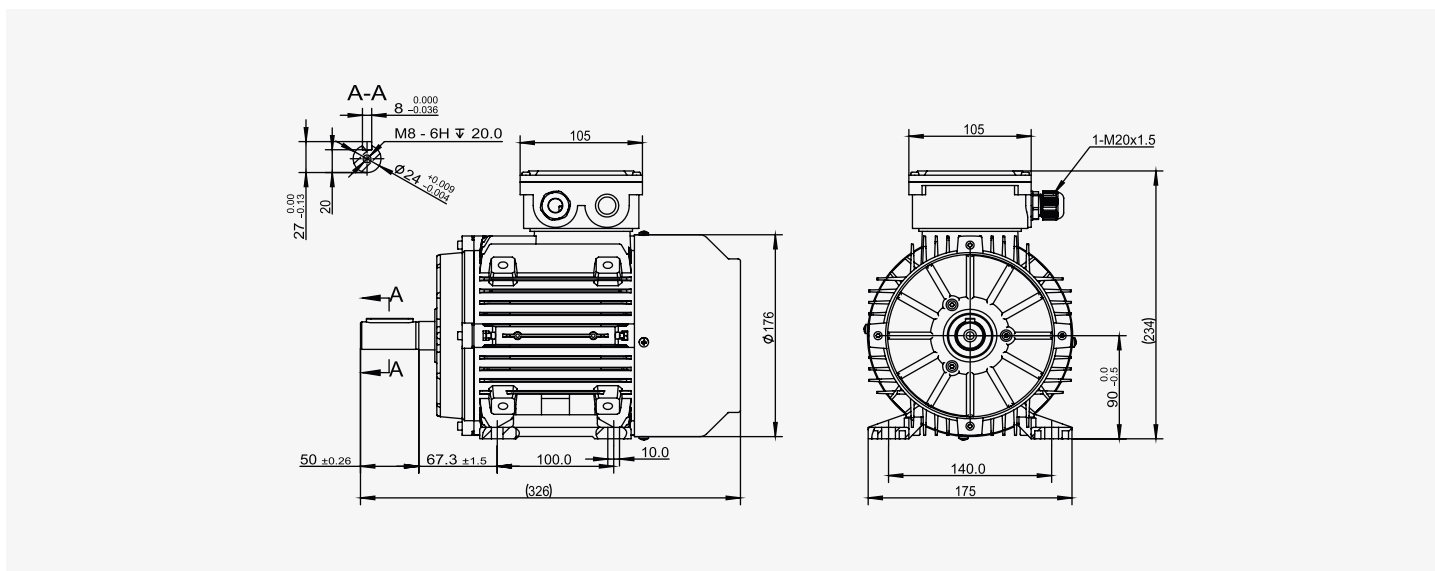

T90ECI motor con accionamiento integrado (B3)

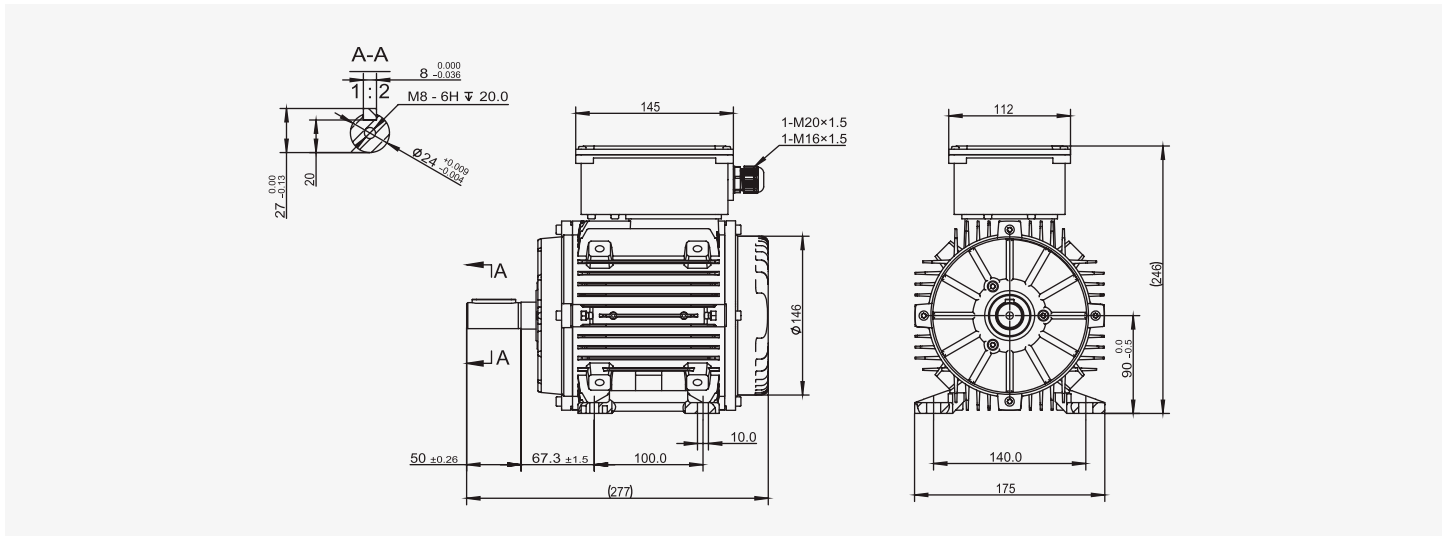

T100EC motor autoventilado (B3, IC411)

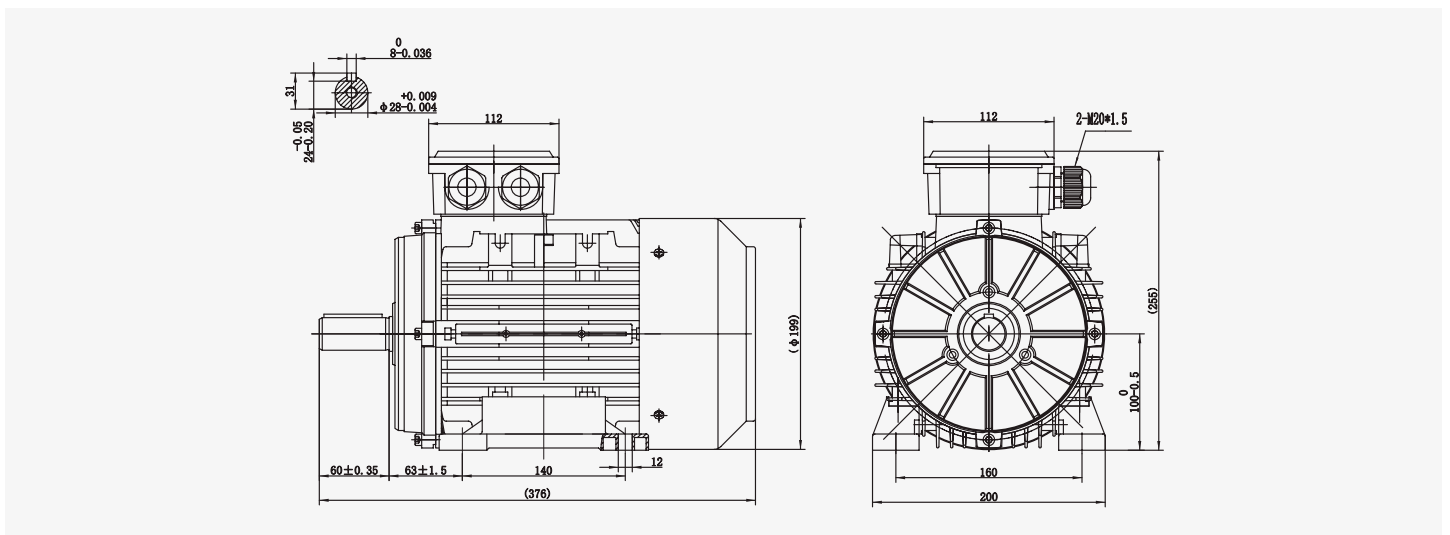

T123EC motor sin ventilación (B3)

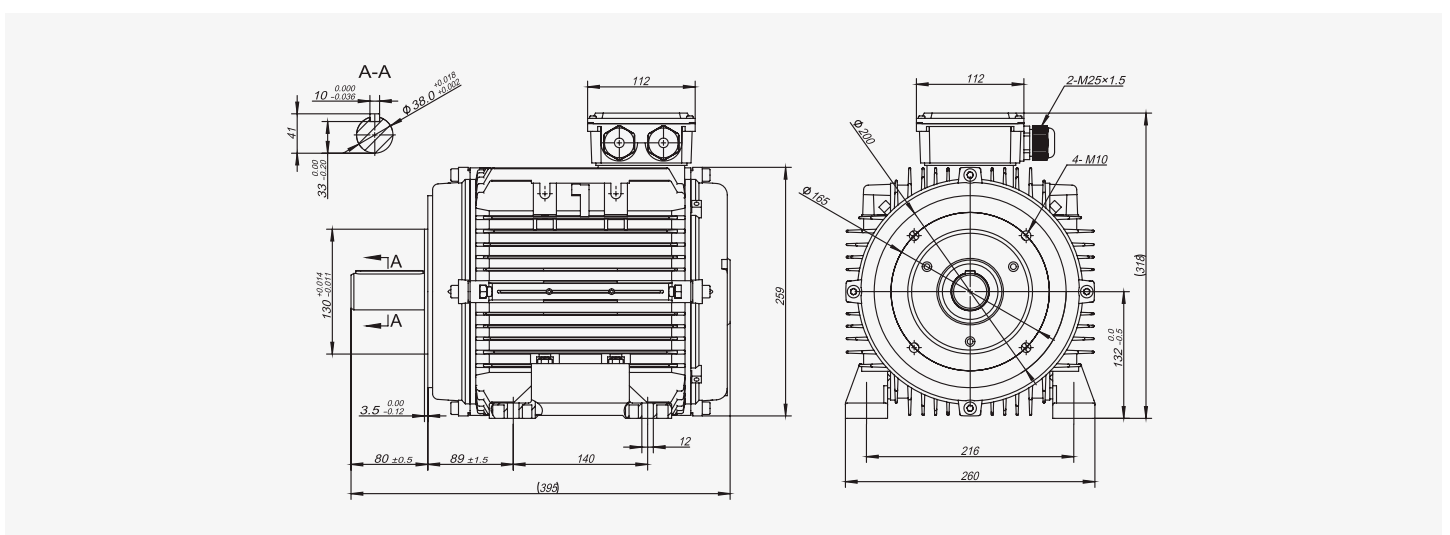

CARACTERÍSTICAS GENERALES

CONEXIONES, RODAMIENTOS, CERTIFICADOS Y DETALLE DE PLACA DE CARACTERÍSTICAS

CONEXIONES

Motores trifásicos TA y TC

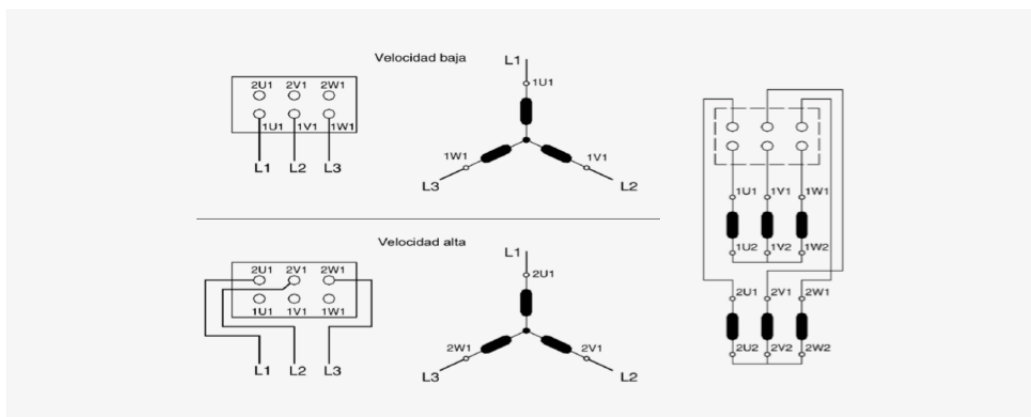
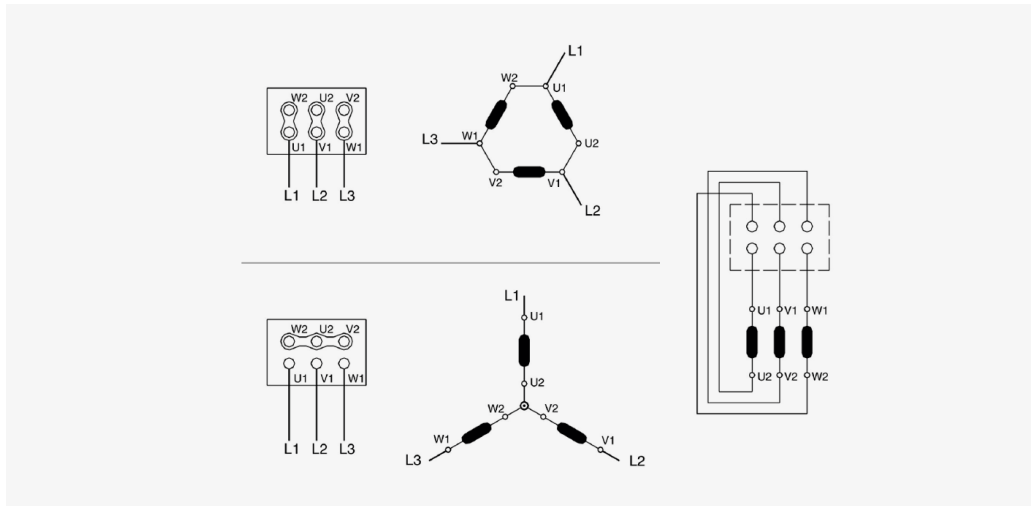
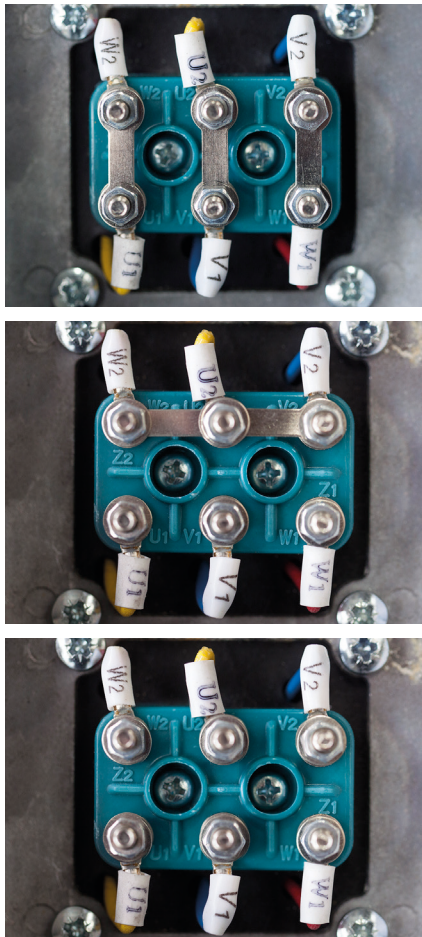

Motores monofásicos MY y ML

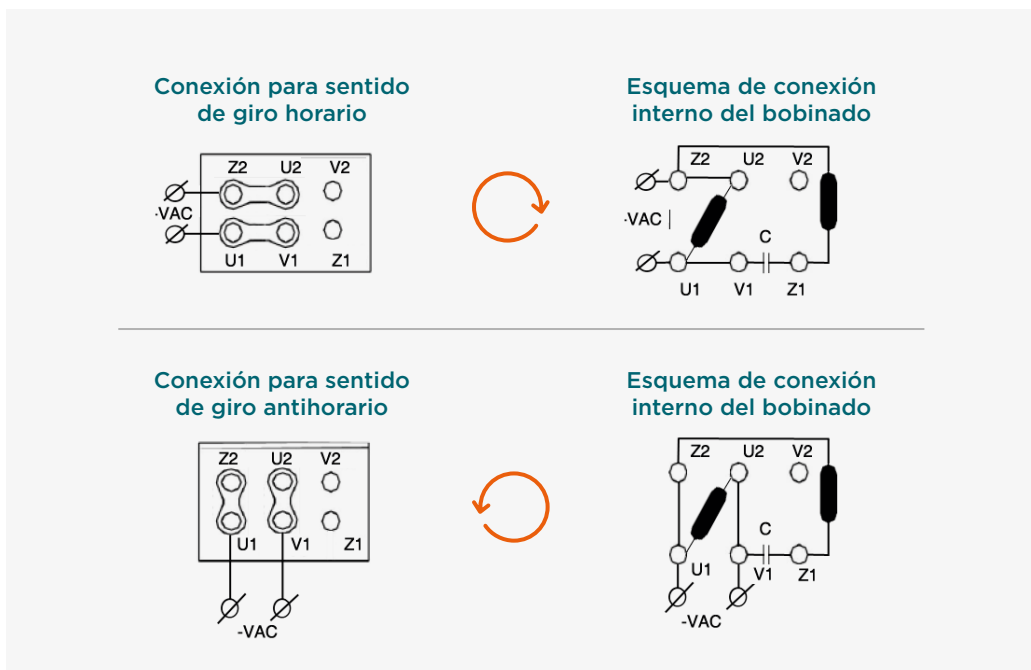
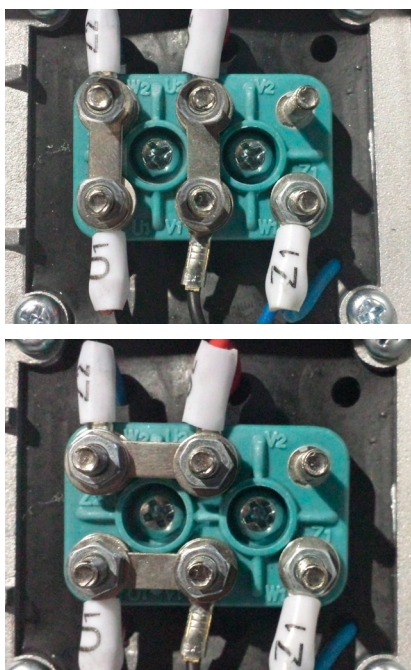

RODAMIENTOS

Tipo	Nº Polos	Rodamientos		Retén
		Lado accionamiento	Lado ventilación	
TA 56	2/4/6/8	6201-2RS-C3	6201-2RS-C3	12x22x5
TA 63	2/4/6/8	6201-2RS-C3	6201-2RS-C3	12x22x5
TA 71	2/4/6/8	6202-2RS-C3	6202-2RS-C3	15x25x7
TA 80	2/4/6/8	6204-2RS-C3	6204-2RS-C3	20x34x7
TA 90	2/4/6/8	6205-2RS-C3	6205-2RS-C3	25x37x7
TA 100	2/4/6/8	6206-2RS-C3	6206-2RS-C3	30x44x7
TA 112	2/4/6/8	6306-2RS-C3	6206-2RS-C3	30x44x7
TA 132	2/4/6/8	6308-2RS-C3	6208-2RS-C3	40x58x7
TA 160	2/4/6/8	6309-2RS-C3	6209-2RS-C3	45x65x8
TA 180	2/4/6/8	6311-2RS-C3	6211-2RS-C3	55x72x8
TA 200	2/4/6/8	6312-2RS-C3	6212-2RS-C3	60x80x8
TC 132	2/4/6/8	6308ZZ-C3	6208-2RS-C3	40x58x7
TC 160	2/4/6/8	6309-C3	6309-C3	45x65x8
TC 180	2/4/6/8	6311-C3	6311-C3	55x75x8
TC 200	2/4/6/8	6312-C3	6312-C3	60x80x8
TC 225	2/4/6/8	6313-C3	6313-C3	65x90x10
TC 250	2/4/6/8	6314-C3	6314-C3	70x95x10
TC 280	2/4/6/8	6316-C3	6316-C3	80x100x10
TC 315	2	6317-C3	6317-C3	85x110x12
TC 315	4/6/8	NU319	6319-C3	95x120x12
TC 355	2	6319-C3	6319-C3	95x120x12
TC 355	4/6/8	NU322	6322-C3	110x130x12

Rodamiento aislado disponible bajo pedido.

Montaje vertical: consultar oficina técnica.

CERTIFICACIONES



ISO 9001:2008
GB/T19001-2008



ISO 14001:2004
GB/T24002004

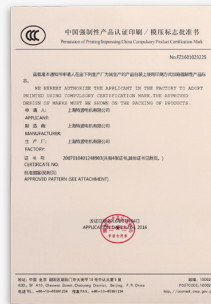

Certificado CCC



LV Directive 2014/35/EU
EC Directive 2014/30/EU

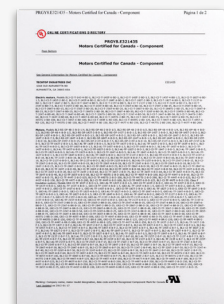

Certificado UL



CSA US Compliance
N°2073480

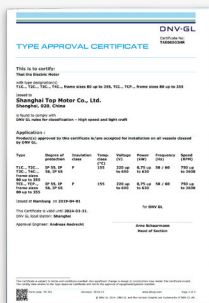

Certificación DNV-GL

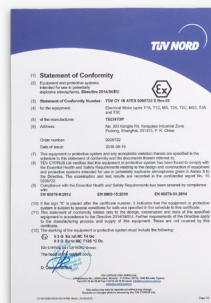

Directiva ATEX
Zonas 2 y 22



Certificado EAC



Certificaciones RoHS,
Firepump, EE

DETALLE PLACAS DE CARACTERÍSTICAS

SERIE TA

TECHTOP MOTOR							Energy Verified Only	Energy Verified Only	Energy Verified Only	Energy Verified Only	Energy Verified Only
TYPE: T802-4 T3A 802-4				(H)	S1-100%	2019	IEC60034				
SN 011909021137			ThCl. F	IP55	IM B3	N.W.: 11.7 KGS					
V Δ / Y	Hz	min ⁻¹	kW	A	cos φ	IE3-82.5 (100%)					
230/400	50	1430	0.75	3.11/1.80	0.73	82.5 (75%)					
240/415	50	1440	0.75	13.11/1.80	0.70	80.1 (50%)					
254/440	60	1725	0.75	2.79/1.61	0.73	BEARING DE-NDE: 6304-6204					
265/460	60	1735	0.75	2.75/1.59	0.70						
DIMOTOR S.A. C/Corrals Nous, 61 Sabadell (Spain)											

SERIE TC

TECHTOP MOTOR							Energy Verified Only	Energy Verified Only	Energy Verified Only	Energy Verified Only	
TYPE: T 160M-4 T3CR 160M-4				(H)	S1-100%	2020	IEC60034				
SN 02 191251056			IsI.Cl. F	IP55	IM B3	N.W.: 127 KGS					
V Δ / Y	Hz	min ⁻¹	kW	A	cos φ	IE3-91.4 (100%)					
400/690	50	1450	11	20.68/11.99	0.84	92.2 (75%)					
415/718	50	1450	11	19.93/11.49	0.84	91.7 (50%)					
440/760	60	1740	11	18.8/10.9	0.84	BEARING DE-NDE: 6309-6309					
460/795	60	1740	11	18.0/10.4	0.84						
DIMOTOR S.A. C/Corrals Nous, 61 Sabadell (Spain)											

SERIE MY

TECHTOP MOTOR							CE
TYPE: MY 802-4			S1-100%	(H)	IEC60034		
SN No. 1803-24 1181			Ins.Cl. F	IP55	2018	IM B5	
V	Hz	min ⁻¹	kW	A	cos φ	Capacitor	
230	50	1420	0.75	4.42	0.99	30 μF 450 V	
DE 6204				NDE 6204			
DIMOTOR S.A. C/Corrals Nous, 61 Sabadell (Spain)							

SERIE ML

TECHTOP MOTOR							CE
TYPE: ML 90L-2			S1-100%	(H)	IEC60034		
SN No. 2002-02 098			Ins.Cl. F	IP55	2020	IM B34	
V	Hz	min ⁻¹	kW	A	cos φ	Capacitor	
230	50	2850	2.2	11.9	0.99	250/50 μF 300/450 V	
DE 6205				NDE 6205			
DIMOTOR S.A. C/Corrals Nous, 61 Sabadell (Spain)							

CONFIGURADOR TECHTOP

- ✔ Ficha técnica de motores
- ✔ Planos 2D (.dwg / .pdf)
- ✔ Planos 3D (.step)

OPTIMIZA TODOS LOS MOTORES TECHTOP SEGÚN SUS NECESIDADES

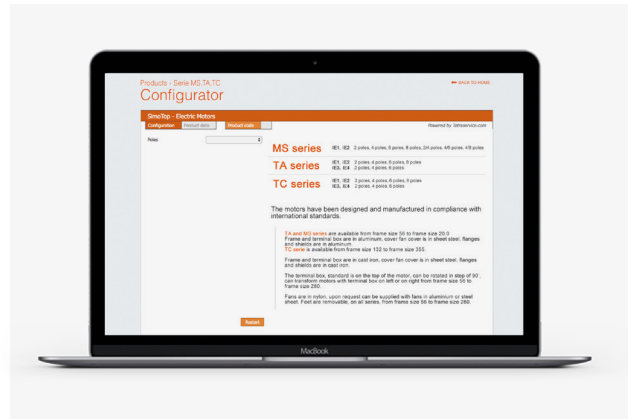

- Techtop pone a su disposición una herramienta que le permite configurar todos los motores del catálogo de manera rápida, eficiente y estructurada. Configure su motor y descárguese toda la documentación que necesita: Ficha técnica del motor, planos 2D y 3D.

TECHTOP Data sheet for three-phase squirrel-cage motor

Type T3A 100L1-4 Cod. R100L402_Z3A8A0000T Mounting position IM B3 IM 1001

Electrical data		General data	
Rated motor power	2.2 kW	Frame size	100
Rated motor speed	1450 rev/min	Mounting	B3
Rated motor frequency	50 Hz	Weight	23.7 kg
Rated motor voltage(±10%)	230 V/50Hz	Casting material	Aluminum
	400 V/50Hz	Protection	IP 55
Rated motor torque	14.5 Nm (10.1 lb-ft)	Topolization	Yes
	480 V/60Hz	Inversion class	A
Rated motor current	7.75 A/50Hz	Duty	S1
	4.5 A/60Hz	Direction of rotation	Reversible
Starting motor current	7.9 A	Method of cooling	IC - 411
Starting motor torque	2.8 Nm	Cable entry	3xØ20x1.5
Breakdown motor torque	3.3 Nm	Standards	IEC60000/IEC529
Starting	TDCL	Encoder at Standard	IC 80304.1
Efficiency class	IE3	Paint treatment	Yes
50Hz	80.4	Paintwork	RAL 7024 / Standard
80.7	80.9	Thermal protection	PTC 100°C
81.2	81.3	IE3 conditions	
81.2	81.6	Ambient temperature	From -20°C to +40°C
0.82	0.82	Altitude above sea level	1000 m

MECHANICAL DATA

Shaft level	LMA	SO	ØSHA	Bearing OE size	ISO-285-C3
Shaft level	LMA	SO	ØSHA	Bearing NDE size	ISO-285-C3
Mount of inertia	0.02475	kgm²		Arrange bearing distance	6000
Bearing type	NDE			Reinforcement Interval, L1 OE bearing	1h
				Reinforcement Interval, L1 NDE bearing	1h
				Compression ring	NDE: ISOE Standard

SHANGHAI TOP MOTOR CO., LTD.
800 001 881666 Road Shanghai Town, Pudong, Shanghai, 201333, China
Tel: +86-21-44393304 www.techtop.com

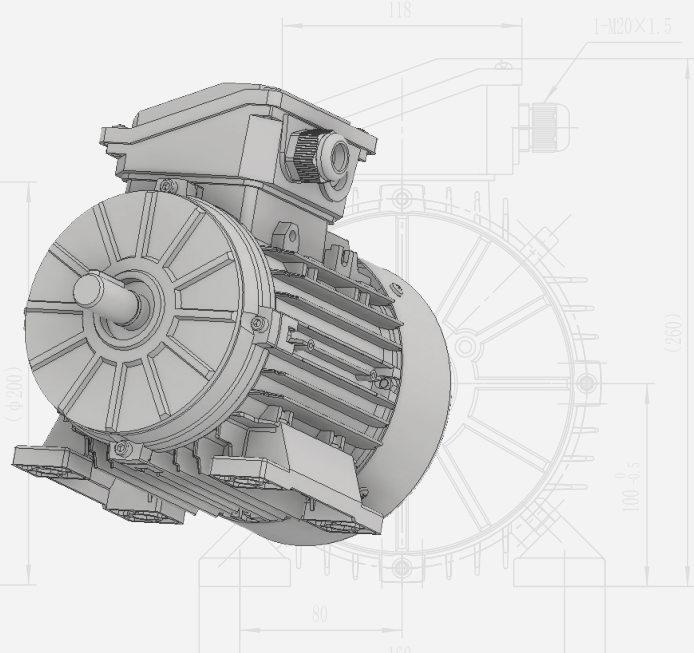

SOPORTE DOCUMENTAL

- ✔ Ficha técnica de accesorios
- ✔ Test report & curvas
- ✔ Manuales de instalación, funcionamiento, mantenimiento y seguridad
- ✔ Certificados

Nuestra oficina técnica está a su completa disposición para facilitar toda la documentación técnica relativa a nuestros motores eléctricos Techtop.

Contacte con dimotor@dimotor.com o llame al (+34) 937 180 200 para solicitar toda la información que necesite.

CENTRAL | SABADELL

Carrer Corral nous, 61. P.I Can Roqueta 08202
Sabadell. Barcelona - España
T. (+34) 937 180 200
F. (+34) 937 198 090
dimotor@dimotor.com

DELEGACIÓN | ZAMUDIO

Poligono Ugaldeguren 1, parcela 8, Nave 2-A2
48170 Zamudio Bizkaia - España
T. (+34) 944 578 190
M. (+34) 629 635 515
dimotor@dimotor.com

OFICINA | PORTUGAL

DELEGAÇÃO PORTUGAL
T. (+34) 937 180 200
dimotor@dimotor.com

EL PODER DE UNA RED GLOBAL

Delegación Techtop



Este catálogo contiene solo descripciones generales o prestaciones que en el caso de aplicación concreta pueden no coincidir exactamente con lo descrito, o bien haber sido modificadas como consecuencia de un ulterior desarrollo del producto.